

Part Number Update

Bulletin No: PNU-179

Effective Date: July 19, 2013 Cancells: NA

Page: 1 of 1

Subject: Core Brake Shoe Group Change and Obsolescence

As a result of customer feedback, Bendix is assisting customers returning brake shoe types 4709E and 4709E2 by combining them into a single core group "2X" (the current group for the 4709E2). This change is effective September 1, 2013. Additionally, on that same date, the brake shoe 4701Q will be obsoleted from the Bendix Core system.

Core Group Changes:

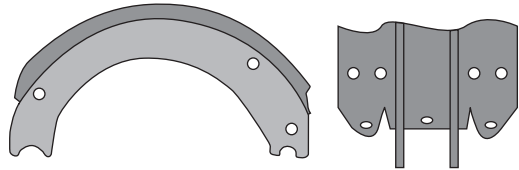
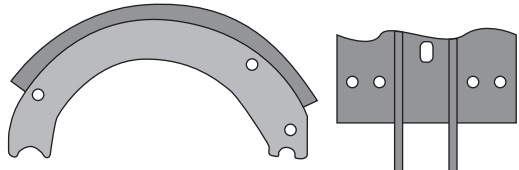
Brake Shoe Type	Previous Core Group	New Core Group
<p>4709E</p> 	2R	2X
<p>4709E2</p> 	2X	

Current eligibility balances of the model 4709E that are in Core Group 2R on August 31, 2013 will be transferred to core group 2X. This transfer will ensure that this Core Group change does not negatively affect any current eligibility in group 2R.

Brake Shoe Obsolescence:

Brake model 4701Q is not a brake shoe remanufactured by Bendix. While similar to model 4515Q (in Core Group 2Q), the 4701Q is not acceptable as a core return in place of the 4515Q. Any 4701Q cores received will not be returned, but will be scrapped, with no credit issued.

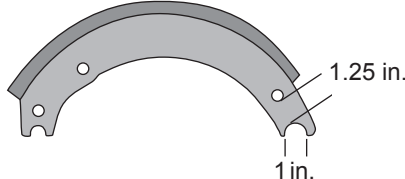
Brake Shoe Type	
<p>4701Q</p> <p>FMSI No. 4701 Diameter 16.5 in. Width 7 in.</p>	

General Reminders

- Please do not return brake shoes in their original boxes.
- Bendix pays freight on core returns that are over 500 pounds and shipped using the Bendix preferred carrier. If you are unsure of the correct carrier, visit www.bendix.biz, call our logistics company at 877-681-1949, or contact the Cores Administrator at 440-329-9298.

