

Technical Bulletin

Bulletin No.: PRO-20-01 Effective Date: 10/1/88 Page: 1 of 3

Subject: **Bendix Disc Brake Shim and O.S. Support Key Kits**

A shim kit designed to compensate for wear between the caliper and anchor plate is now available for all Bendix medium duty hydraulic disc brakes. The new shim kit, part no. 4151706, may be installed on all disc brake assemblies which use the calipers listed below:

<u>BENDIX CALIPER PART NO.</u>	<u>CALIPER PISTON DIA.</u>	<u>DISC PAD PART NO.</u>	<u>MOST COMMON APPLICATION</u>
55098	3.38" S.P.	MKD184	Navistar 1600
55099	3.38" S.P.	MKD184	Navistar 1600
55245	2.6" T.P.	MKD184	Navistar
55250	2.88" T.P.	MKD225	GM/Chevy

SHIM KIT 4151706 CANNOT BE INSTALLED ON LIGHT TRUCK VERSIONS OF THE 3.38" SINGLE PISTON DISC BRAKE. The light truck, 3.38" single piston calipers listed below, require the use of over-sized caliper retainer keys rather than shims.

<u>BENDIX CALIPER PART NO.</u>	<u>CALIPER PISTON DIA.</u>	<u>DISC PAD PART NO.</u>	<u>MOST COMMON APPLICATION</u>
55199	3.38" S.P.	MKD149	GM/Chevy
55200	3.38" S.P.	MKD149	GM/Chevy

The light and medium truck version of the 3.38" single piston caliper can be differentiated by the vehicle application and caliper part number. The disc pad can also provide a means of identifying the caliper since different part numbers are used on the light and medium versions.

Shim kit 4151706 contains the following part which are keyed to Figure 1.

KEY	DESCRIPTION	QTY.
A.	Caliper support spring	2
B.	Caliper support key	2
C.	.025" shim	2
C.	.045" shim	2

A typical oversize key kit contains the following parts which are keyed to Figure 1.

KEY	DESCRIPTION	QTY.
A.	Caliper support spring	2
B.	Caliper support key	2
Not Illustrated	Clip	1

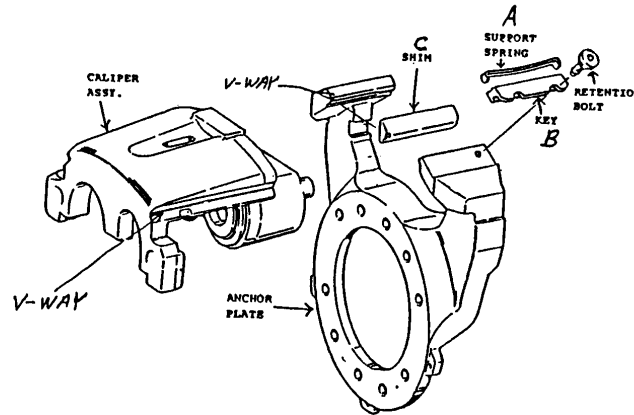

FIGURE 1

The following procedure should be used to determine if an oversize key kit (H5604-H5608) or shim kit (4151706) is required. Refer to Figures 1, 2 & 3.

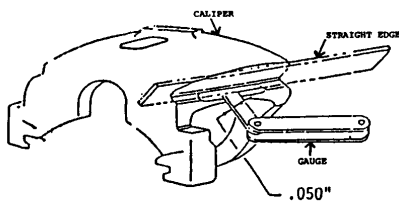

FIGURE 2

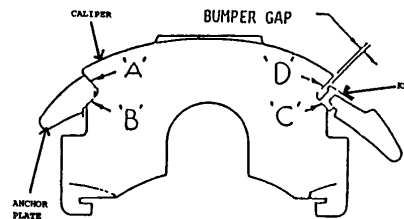

FIGURE 3

1. Remove the caliper assembly from the anchor plate by first removing the key retention bolt and tapping out the key and support spring.
2. Clean the V-way surfaces of the caliper and anchor plate with a wire brush and using a file, smooth any deep nicks and/or gouges.
3. Lay a straight edge across the caliper V-way surfaces as shown in Figure 2 and measure the wear on these surfaces using a feeler gauge. Calipers which display wear of .050" or greater should be replaced.
4. Reinstall the caliper in the anchor plate. Temporarily install a new key *WITHOUT IN STALLING THE SUPPORT SPRING*. Secure the key to the caliper using the retention bolt.

5. Insert a suitable prying tool between the caliper and support key making certain the tool is equally distant from each edge of the caliper. Pry firmly to assure that the caliper is seated against the three (3) sliding surfaces (A, B & C) illustrated in Figure 3.
6. Measure the "bumper" gap formed between the key and caliper using a feeler gauge or stack of feeler gauges. *MAKE THIS MEASUREMENT ON ONE SIDE OF THE PRYING TOOL THEN THE OTHER.*
7. Using the bumper gap measurement select the appropriate shim kit or oversize key kit.

SHIM KIT 4151706
FOR MEDIUM TRUCK DISC BRAKES ONLY

<u>MEASURED BUMPER GAP</u>	<u>SHIM THICKNESS REQUIRED</u>
0.0 " to .058"	No Shim Required
.059" to .101"	.025" Shim
.102" to .145"	.045" Shim
Greater than .145" -----	SEE CAUTION BELOW

OVERSIZE KEY KITS
FOR LIGHT TRUCK 3.38"
DISC BRAKES ONLY

<u>MEASURED BUMPER GAP</u>	<u>KEY SIZE</u>	<u>KIT PART NO.</u>
0.0" to .060"	STD.	H5604
.061" to .100"	.040" O.S.	H5605
.101" to .140"	.080" O.S.	H5606
.141" to .180"	.120" O.S.	H5607
.181" to .220"	.160" O.S.	H5608
Greater than .220" -----	SEE CAUTION BELOW	

CAUTION

If the measured bumper gap exceeds the maximum shown for the shim or oversize key kit, it will be necessary to replace the caliper or anchor plate, or both. To determine which component must be replaced, install a *new caliper* in the existing anchor plate and again measure the "bumper gap." If the "bumper gap" is less than the maximum shown, select the appropriate key kit or shim. If the "bumper gap" is greater than the maximum shown, then replace the anchor plate and remeasure using the old caliper. If the "bumper gap" is still greater than the maximum shown, install the new caliper on the new anchor plate.

