

# Technical Bulletin

Bulletin No: PRO-01-07-A

Effective Date: 6/15/80

Cancels: PRO-01-07 dated 4/5/77

Page: 1 of 3

**Subject: MACK TRUCK – INSTALLATION OF POWER STEERING PUMPS ON TU-FLO 500, 501 AND 600 COMPRESSORS**

REF: Mack Bulletin R47 (Attached)

The attached Mack Service Bulletin No. R47 dated 11/19/76 details and illustrates the various mounting configurations and interchangeability of the compressor mounted power steering pumps. Please note that Mack uses two different sets of drive components to mount the pumps on the rear of Bendix compressors. The drive components used depends on the compressor model. The compressor and drive component combinations are as follows:

COMPRESSOR	POWER STEERING PUMP - DRIVE HOUSING - (Mack Part No.)	POWER STEERING PUMP - COUPLING HUB – (Mack Part No.)
Tu-Flo 501	756GB326	792GB219
Tu-Flo 500, 600 & 700	756GB217	792GB17

Drive components are obtained through Mack parts outlets.

If it becomes necessary or desirable to change over from one model compressor to another, it may also be necessary to change the drive components. (i.e.: Changeover from T/F 501 to T/F 700.)

The following is a list of Bendix compressors which accept the rear mounted Mack power steering pumps.

COMPRESSOR	BENDIX O.E. PIECE NO.	MACK PIECE NO.	FURNISH REMAN. PC. NO.
Tu-Flo 500	284581	303GB 572-P5	284662
	*285204	303GB 4181	285205
Tu-Flo 600	285100	303GB 4170R-P3	285108
	*286220	303GB 4170R-P4	286221
Tu-Flo 501	286004	303GB 575R-P1	286544 or 286583
	288982	303GB 580R-P1	286544 or 286583
Tu-Flo 700	289251	303GB 4201R	289340

\*With steel connecting rods



# SERVICE BULLETIN

NOVEMBER 19, 1976

No. R47 under STEERING

FOR BRANCHES, DISTRIBUTORS AND CUSTOMERS. (Supersedes Bulletin dated JUNE 18, 1975)

CHASSIS AFFECTED ALLENTOWN  HAYWARD  OAKVILLE

## ALTERNATE STEERING PUMP

(R, U, DM600, MB, FL and FS)

**PURPOSE** To inform the field of an alternate steering pump and also to list parts required to interchange this pump with standard pump. This applies to steering pumps mounted on TU-FLO 500, TU-FLO501, TU-FLO 600, or Midland-Ross air compressors.

**RECOMMENDATION** If a replacement steering pump of original type is not available, the alternate pump can be substituted as outlined in bulletin.

**INFORMATION** A Parker-Hannifin pump has been released for production use. This pump is interchangeable with a Vickers pump if the correct drive housing and related parts are used.

### IMPORTANT

It is recommended that the Parker-Hannifin pump be restricted to following applications. See Figure 1.

Allentown Models - Use only on chassis equipped with Ross SGP48 integral power steering gear or Ross Inline Booster (MB) as its output matches these units.

Mack Western Models - Chassis with Mack Six Cylinder engine and Ross or Garrison power steering.

The following charts show parts required for the various combinations of pumps and compressors. Note from the illustration that the TU-FLO 501 and TU-FLO 500 and 600 arrangements are similar except that the TU-FLO 500 and 600 coupling hub is attached with three screws instead of one. Due to differences in port sizes between the two pumps, some hose fitting changes will be required when making the change; hose sizes remain the same.

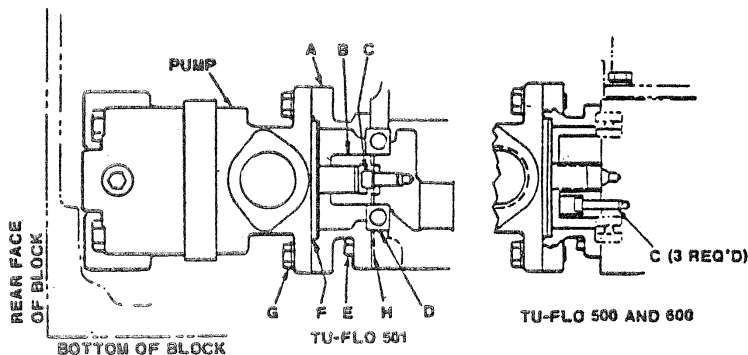

FIGURE 1  
PUMP MOUNTING ARRANGEMENT

(Continued Over)

Service Operations, Allentown, Pa. U.S.A.

**Mack**

ALLENTOWN CHASSIS

Key	Qty.	Component	Part Number			
			TU-FLO 501 & Midland-Ross		TU-FLO 500 and 600	
			Vickers	Parker-Hann.	Vickers	Parker-Hann.
		Pump (MB) Pump (R,U,DM)	38QC375-P3 38QC375-P2	38QC461-P3 38QC461-P2	38QC375-P3 38QC375-P2	38QC461-P3 38QC461-P2
A	1	Drive Housing	756GB317	756GB317	756GB28	756GB28
B	1	Pump Coupling Hub	792GB219	792GB219	792GB17	792GB17
C	1	Pump Coupling Hub Screw	3AX1825	3AX1825	(3)3AX1772	(3)3AX1772
D	1	Gasket Oil Seal, Comp. -to-Drive Housing	446GC1175-P3	446GC1175-P3	446GC1175-P2	446GC1175-P2
E	--	Drive Housing Mounting Hardware	Furnished W/Compressor		Furnished W/Compressor	
F	1	Oil Seal, Drive Housing-to-pump	446GC1175-P1	*120MF145	446GC1175-P2	*120MF145
G	2	Screw, Pump Mounting	4AX16	4AX3	4AX16	4AX3
	2	Lockwasher, Pump Mounting	36AX3	36AX3	36AX3	36AX3
H	2	Seal, Drive Housing	8QD1005	8QD1005	-----	-----
--	--	Discharge Fitting			63AX3477	
--	--	Bypass Elbow			63AX737	
--	--	Bypass Hose Fitting			63AX3332	
--	--	Suction Fitting	63AX2057	63AX3127	63AX2057	63AX3127

\* Also apply a coat of Silastic 732RTV to pump mounting flange.

MACK WESTERN CHASSIS

NOTE

Pumps for under 12,000# capacity are to be utilized for units with Garrison power steering.

KEY	QTY.	COMPONENT	PART NUMBER			
			TU-FLO 501 & Midland-Ross		TU-FLO 500 - 600	
			VICKERS	PARKER-HANNIFIN	VICKERS	PARKER-HANNIFIN
		Pump	38QC367-P4 12,000# and Over 38QC19303-P8 Under 12,000 #	38QC19313-P2 12,000# and Over 38QC19313-P1 Under 12,000 #	38QC367-P4 12,000# and Over 38QC19303-P8 Under 12,000#	38QC19313-P2 12,000# and Over 38QC19313-P1 Under 12,000#
A	1	Drive Housing	756GB317	756GB317	756GB28	756GB28
B	1	Pump Coupling Hub	792GB219	792GB219	792GB17	792GB17
C	1	Pump Coupling Hub Screw	3AX1825	3AX1825	3AX1772	3AX1772
D	1	Gasket-Oil Seal Comp. to Drive Housing	446GC1175-P3	120MF145	446GC1175-P2	120MF145
E	---	Drive Hsg. Mtg. Hardware	Furnished W/Compressor		Furnished W/Compressor	
F	1	Oil Seal-Drive Hsg. to Pump	446GC1175-P1	446GC1175-P1	446GC1175-P1	446GC1175-P1
G	2	Screw-Pump-Mounting	4AX16	4AX16	4AX16	4AX16
	2	L/W-Pump-Mounting	36AX3	36AX3	36AX3	36AX3
H	2	Seal-Drive Housing	-----	-----	-----	-----
		Discharge Fitting	56AX379-"O" Ring 63AX3263-Conn.	56AX379-"O" Ring 63AX3477-Elbow	56AX379-"O" Ring 63AX3263-Conn.	56AX379-"O" Ring 63AX3477-Elbow
		Bypass Elbow	63AX1740-Conn.	56AX410-"O" Ring 63AX3331-Elbow	63AX1740-Conn.	56AX410-"O" Ring 63AX3331-Elbow
		Suction Fitting	38QC29301	63AX3492 Elbow 83AX827 Clamp *6835-05HP-16 Plug	38QC29301	63AX3492-Elbow 83AX627 Clamp *6635-05HP-16 Plug

\* Required to plug side supply port - See Figure 2

