

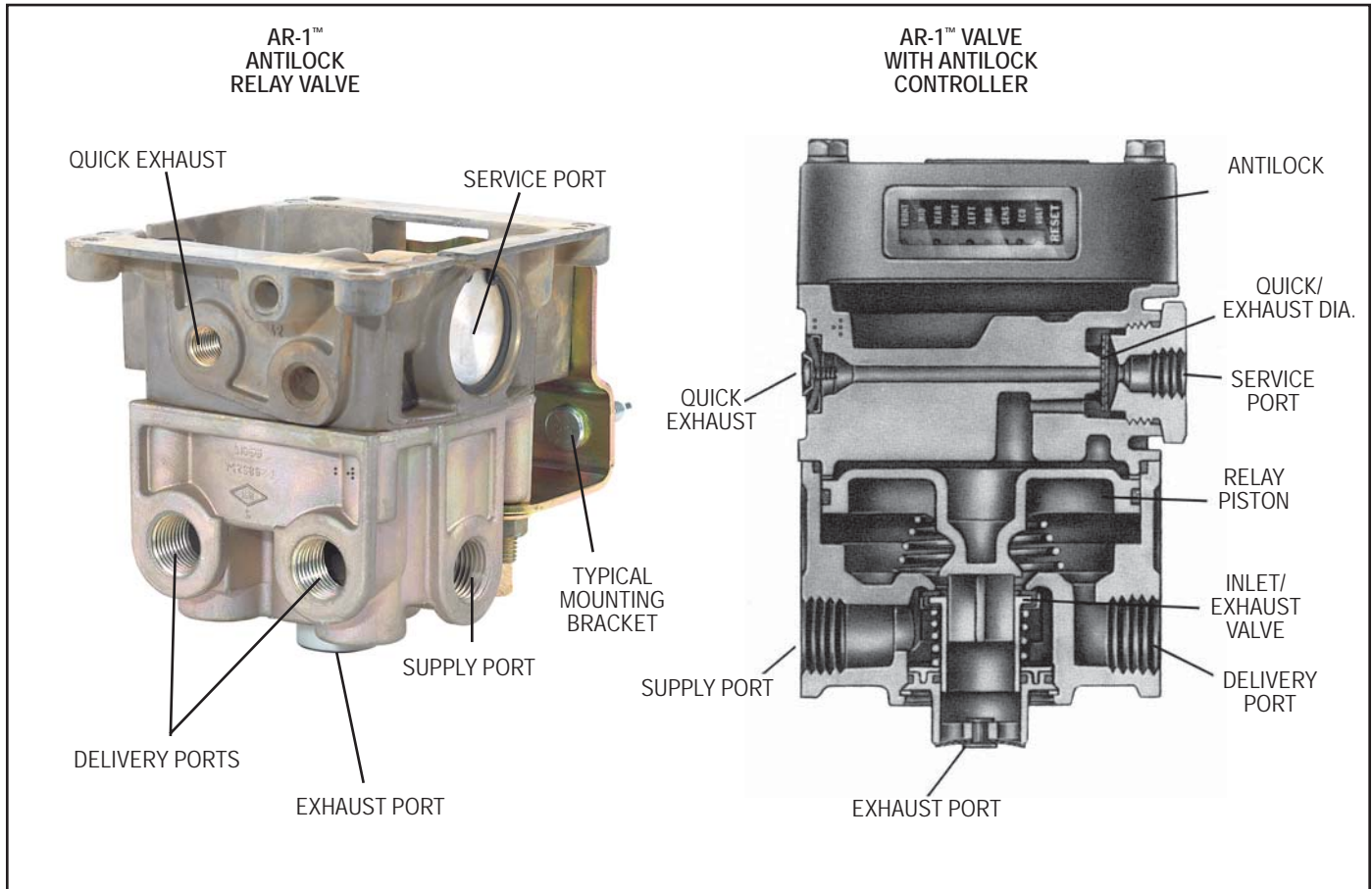

# Service Data

SD-13-4795

## Bendix® AR-1™ AntiLock Relay Valve



### DESCRIPTION

The AR-1™ antilock relay valve (*Figure 1*) is a specialized service brake relay valve. It is essentially an R-14™ relay valve with a special cover that permits direct attachment of an antilock controller. When combined with an antilock controller the resulting assembly is referred to as an antilock relay controller. For example when the AR-1™ antilock relay valve is combined with the EC-30™ tractor antilock controller the resulting assembly is referred to as a CR-30™ antilock relay controller. While intended for use on antilock equipped vehicles, the AR-1™ antilock relay valve functions solely as a service brake relay and contains no electronics of its own.

In an air brake system, the AR-1™ valve serves as a relay station to speed the application and release of the service brakes. The valve is normally mounted in

FIGURE 1 - AR-1™ ANTILOCK RELAY VALVE ASSEMBLY

proximity to the service actuators it serves. A mounting bracket furnished with the valve permits either frame or cross member mounting. All air connections on the AR-1™ valve are identified with cast, embossed letters for ease of installation. The letter identification and air line connections are shown below for reference.

### AR-1™ VALVE

AIR CONNECTION	EMBOSSED IDENT.
Supply (to reservoir)	SUP
Delivery (to brake actuator)	DEL
Service (to brake valve rear service delivery)	SER

Like the R-14® relay valve, the AR-1™ valve incorporates a quick release valve adjacent to the service port which provides for rapid exhaust of control air pressure from

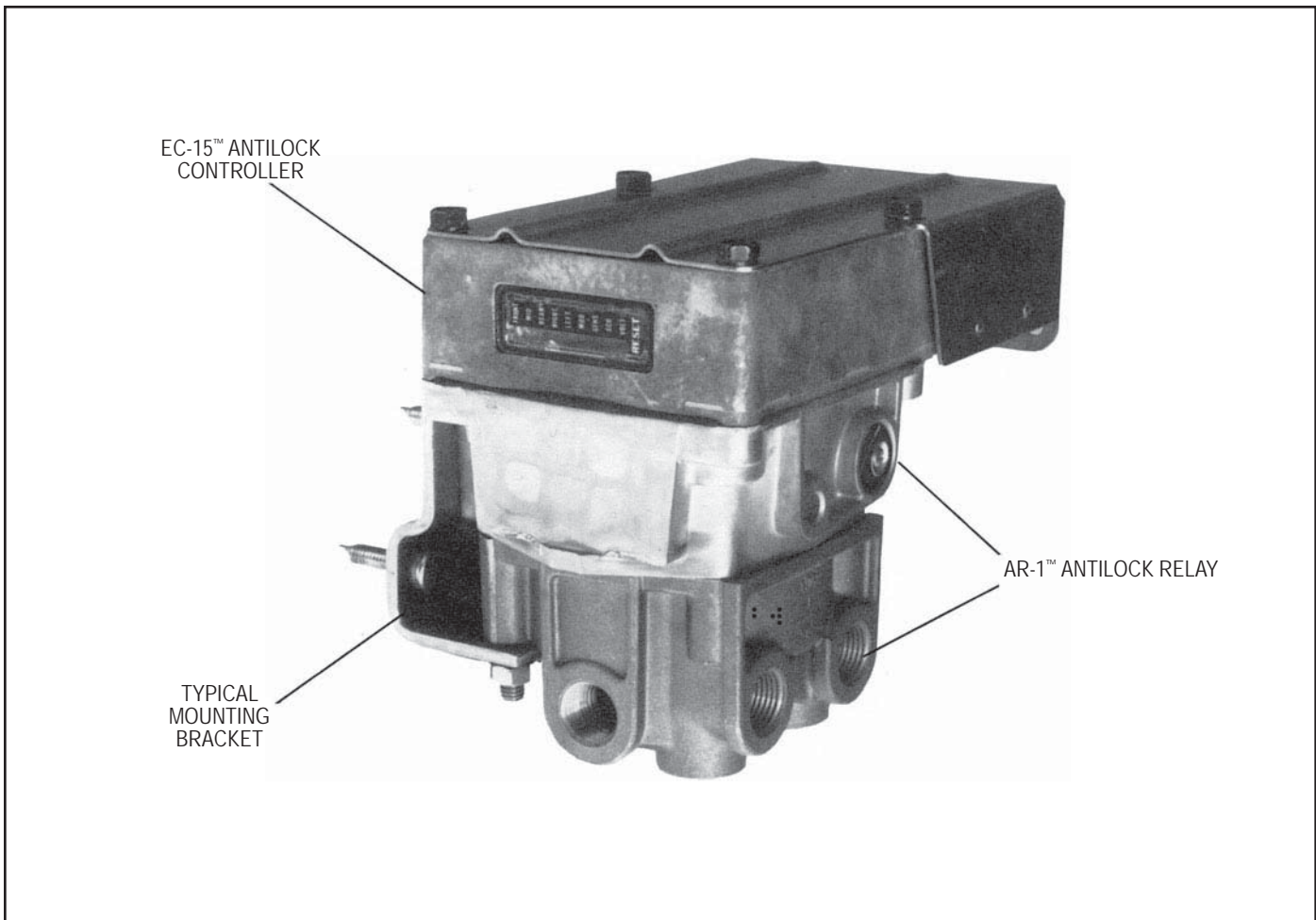

FIGURE 2 - CR-15™ ANTILOCK RELAY CONTROLLER

above the relay piston. The standard AR-1™ valve is offered with a 4 psi crack pressure however with the addition of a various springs beneath the relay piston higher crack pressures are possible.

The AR-1™ valve's internal components are interchangeable with the R-12® and R-14® relay valves therefore the same maintenance kit is used to service all three valves.

## OPERATION

### BRAKE APPLICATION

Brake application air enters the AR-1™ valve's service port and encounters the exhaust diaphragm which flexes in response to the incoming air, sealing the exhaust passage in the cover. Air flows around the exhaust diaphragm and moves through a passage in the cover to the top of the relay piston. In response to air pressure, the relay piston moves into contact with the exhaust portion of the inlet and exhaust valve. With the exhaust passage sealed, continued movement of the relay piston unseats the inlet portion of the inlet and exhaust valve, allowing supply air from the reservoir to flow out the AR-1™ valve's delivery ports to the antilock modulators and then to the brake actuators. (Figure 3)

### HOLDING-BALANCED

The air pressure being delivered to the antilock modulators and brake actuators is also present beneath the relay piston. When the air pressure above and below relay piston is equal, the piston moves slightly allowing the inlet valve to return to its seat. The exhaust valve remains closed. With both the inlet and exhaust valves closed, air pressure in the antilock modulators and brake actuators is held stable and neither increases nor decreases. (Figure 4)

### EXHAUST - BRAKE RELEASE

When the brake application is released, air pressure in the service port of the AR-1™ valve returns to the foot brake valve and is exhausted. Air, from above the relay piston, flows back through the cover to the exhaust diaphragm. The diaphragm flexes in response to the returning air, sealing the service port and opening the exhaust in the cover. With the exhaust diaphragm blocking the service port, returning air flows out the open exhaust. As air pressure is reduced above the relay piston, pressure beneath it lifts the piston away from the exhaust valve and opens the exhaust passage. Air from the antilock modulators and brake actuators returns to the AR-1™ valve and flows out the open exhaust. (Figure 5)

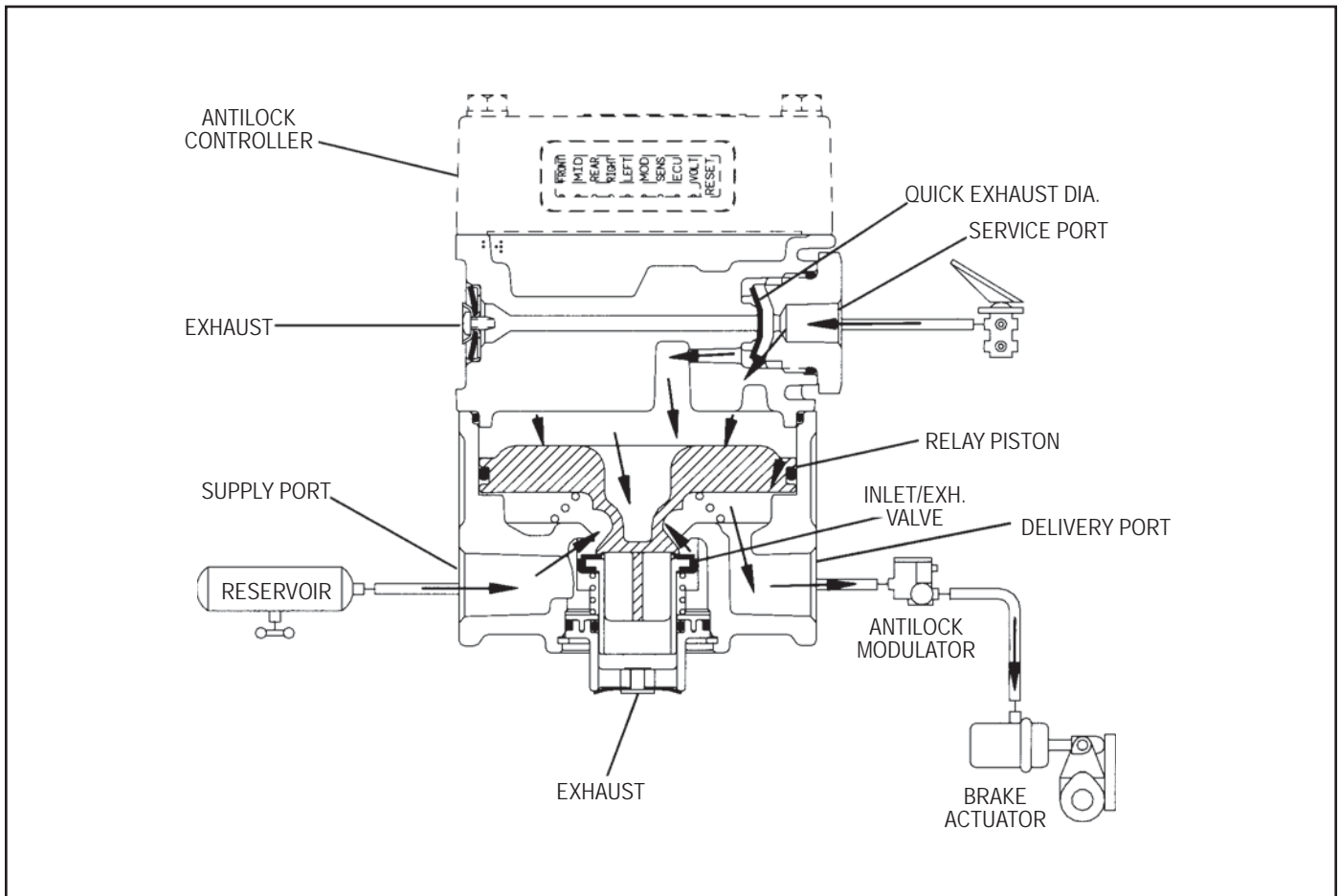

FIGURE 3 - AR-1™ VALVE BRAKE APPLICATION

## PREVENTIVE MAINTENANCE

**Important:** Review the warranty policy before performing any intrusive maintenance procedures. An extended warranty may be voided if intrusive maintenance is performed during this period.

Because no two vehicles operate under identical conditions, maintenance intervals will vary. Experience is a valuable guide in determining the best maintenance interval for a vehicle.

### GENERAL

Perform the tests and inspections presented at the prescribed intervals. If the AR-1™ valve fails to function as described, or leakage is excessive, it should be repaired or replaced with a new or genuine Bendix remanufactured unit, available at any authorized parts outlet.

### EVERY 3 MONTHS, 25,000 MILES OR 900 OPERATING HOURS

1. Remove any accumulated contaminants and visually inspect the exterior for excessive corrosion and physical damage.
2. Inspect all air lines connected to the AR-1™ valve for signs of wear or physical damage. Replace as necessary.

3. Test air line fittings for excessive leakage and tighten or replace as necessary.
4. Perform the Leakage Test described in this manual.

### EVERY YEAR, 100,000 MILES, OR 3,600 OPERATING HOURS

1. Perform the Operation and Leakage Tests described in this manual.

## OPERATION & LEAKAGE TESTS

### OPERATING TEST

1. Apply and release the brakes several times and check for prompt application and release at each wheel. If prompt reaction is noted at some, but *not all* wheels, test the AntiLock modulator between the AR-1™ valve and the brake actuator for proper operation. If a “sluggish” response is noted at all wheels, inspect for a kinked or obstructed air line leading to or from the AR-1™ valve.
2. If a complete release of the brakes is noted at some, but *not all* wheels, test the antilock modulator between the AR-1™ valve and the brake actuator for proper operation. If an incomplete release is noted at all wheels, inspect for a kinked or obstructed air line leading to or from the AR-1™ valve.

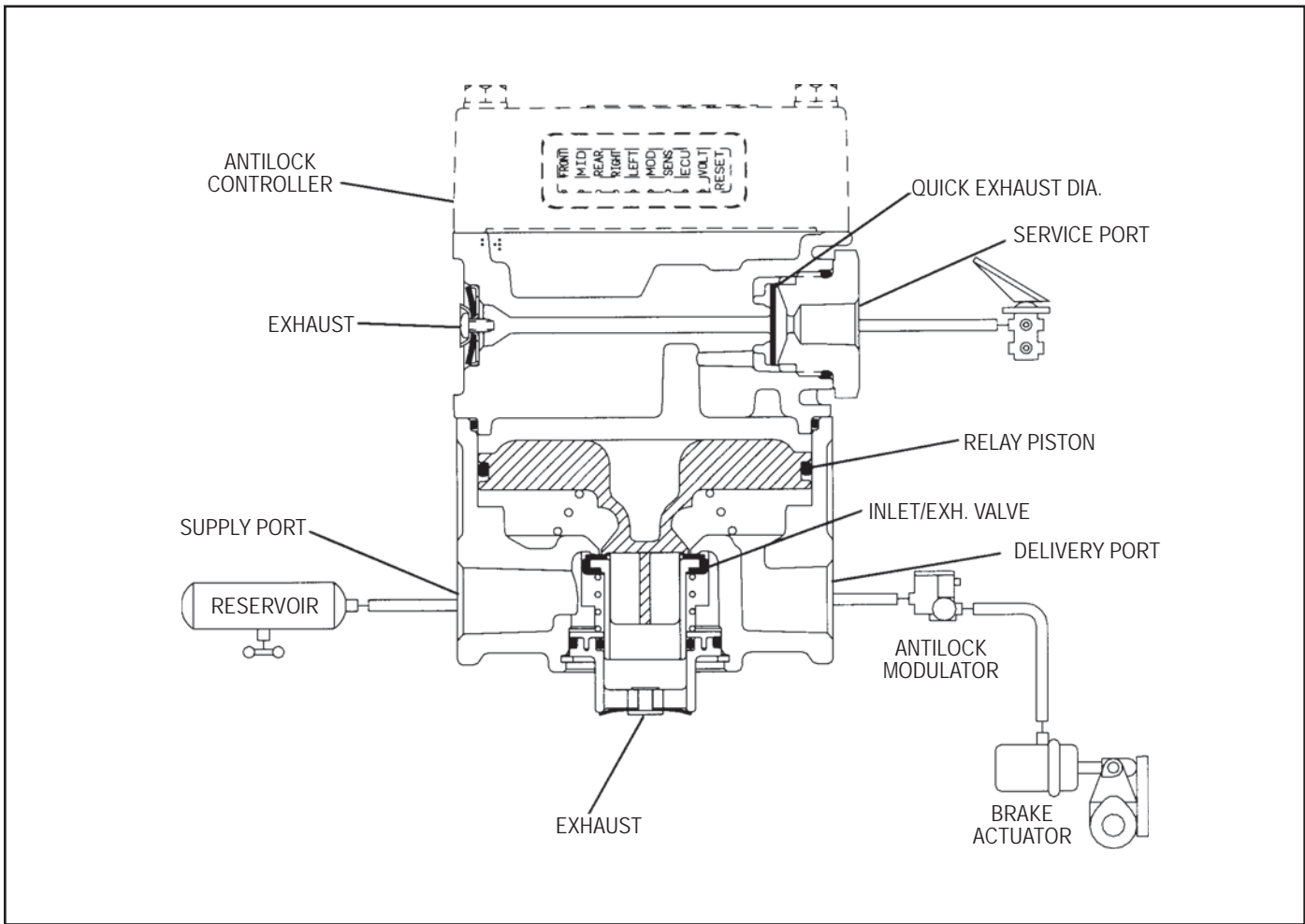

FIGURE 4 - AR-1™ VALVE HOLDING - BALANCED

3. During brake release confirm that a slight “puff” of air exits at the AR-1™ valve’s quick exhaust port in the cover. Air exiting at this exhaust port indicates the AR-1™ valve integral quick release is functioning.

**LEAKAGE TESTS**

1. Build the air system pressure to governor cut-out, apply a soap solution to the exhaust port in body. The leakage noted should not exceed a one inch bubble in less than three (3) seconds.
2. Make and hold a full brake application and apply a soap solution to the exhaust ports in the body and cover and around the cover where it joins the body. The leakage noted should not exceed a one inch bubble in less than three (3) seconds at any exhaust port.

**WARNING! PLEASE READ AND FOLLOW THESE INSTRUCTIONS TO AVOID PERSONAL INJURY OR DEATH:**

When working on or around a vehicle, the following general precautions should be observed at all times.

1. Park the vehicle on a level surface, apply the parking brakes, and always block the wheels. Always wear safety glasses.

2. Stop the engine and remove ignition key when working under or around the vehicle. When working in the engine compartment, the engine should be shut off and the ignition key should be removed. Where circumstances require that the engine be in operation, **EXTREME CAUTION** should be used to prevent personal injury resulting from contact with moving, rotating, leaking, heated or electrically charged components.
3. Do not attempt to install, remove, disassemble or assemble a component until you have read and thoroughly understand the recommended procedures. Use only the proper tools and observe all precautions pertaining to use of those tools.
4. If the work is being performed on the vehicle’s air brake system, or any auxiliary pressurized air systems, make certain to drain the air pressure from all reservoirs before beginning **ANY** work on the vehicle. If the vehicle is equipped with an AD-IS® air dryer system or a dryer reservoir module, be sure to drain the purge reservoir.
5. Following the vehicle manufacturer’s recommended procedures, deactivate the electrical system in a manner that safely removes all electrical power from the vehicle.

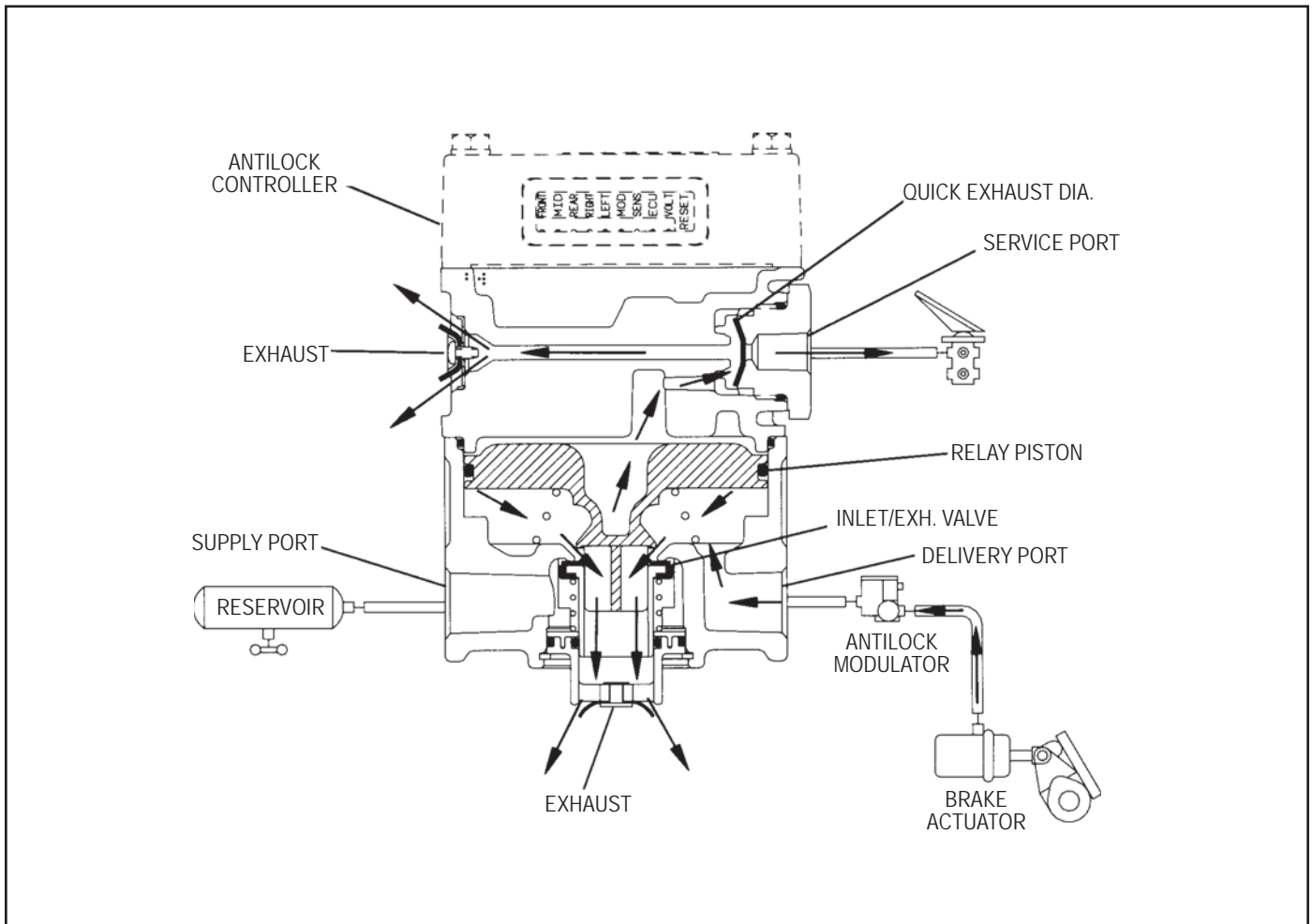

FIGURE 5 - AR-1™ VALVE EXHAUST - BRAKE RELEASE

6. Never exceed manufacturer's recommended pressures.
7. Never connect or disconnect a hose or line containing pressure; it may whip. Never remove a component or plug unless you are certain all system pressure has been depleted.
8. Use only genuine Bendix® replacement parts, components and kits. Replacement hardware, tubing, hose, fittings, etc. must be of equivalent size, type and strength as original equipment and be designed specifically for such applications and systems.
9. Components with stripped threads or damaged parts should be replaced rather than repaired. Do not attempt repairs requiring machining or welding unless specifically stated and approved by the vehicle and component manufacturer.
10. Prior to returning the vehicle to service, make certain all components and systems are restored to their proper operating condition.
11. For vehicles with Antilock Traction Control (ATC), the ATC function must be disabled (ATC indicator lamp should be ON) prior to performing any vehicle maintenance where one or more wheels on a drive axle are lifted off the ground and moving.

## VALVE REMOVAL

1. Park the vehicle on a level surface and block the wheels and/or hold the vehicle by means other than the air brakes.
2. Drain the air pressure from all vehicle reservoirs.
3. Identify, mark or label all air lines and wiring cables and their respective connections on the valve or antilock controller to facilitate ease of installation.
4. Disconnect all air lines and wiring.
5. Remove the valve and controller assembly from the vehicle.

## VALVE INSTALLATION

1. Install all air line fittings and plugs making certain thread sealing material does not enter the valve.
2. Install the assembled valve on the vehicle.
3. Reconnect all air lines and wiring cables to the valve and controller assembly using the identification made during VALVE REMOVAL step 3.
4. After installing the valve and controller assembly, test all air fittings for excessive leakage and tighten as needed.

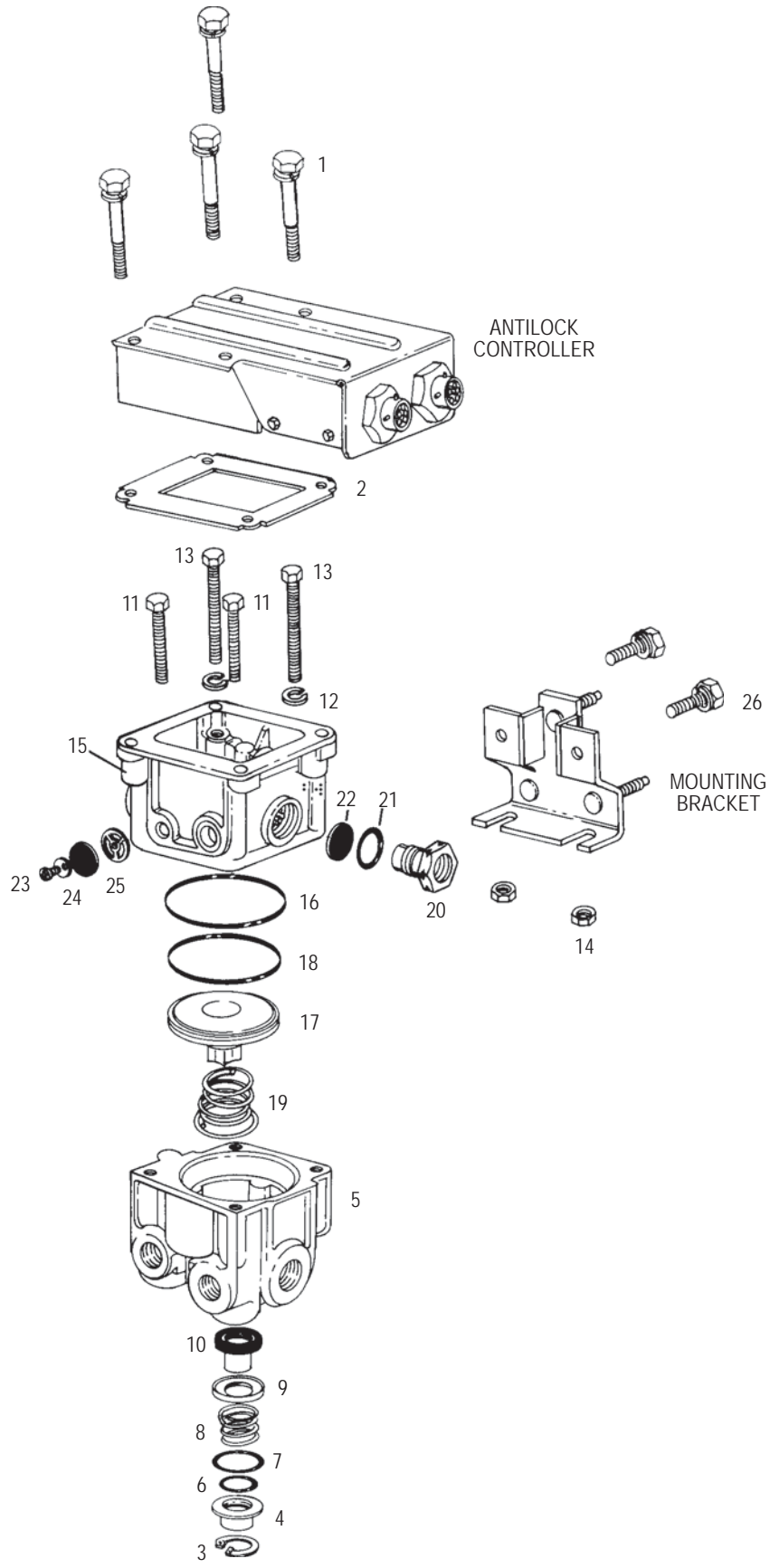

FIGURE 6 - AR-1™ ANTILOCK RELAY VALVE WITH CONTROLLER

## DISASSEMBLY

### GENERAL

The following disassembly and assembly procedure is presented for reference purposes only and presupposes that the appropriate maintenance kit is on hand at the time of disassembly. The instructions provided with the maintenance kit should always be used in lieu of those presented here. Refer to figure 6 throughout the disassembly and assembly procedure.

**CAUTION:** The AR-1™ valve may be lightly clamped in a bench vise during disassembly, however, over clamping will cause damage to the valve and result in leakage and/or malfunction. If a vise is to be used, position the valve so that the jaws bear on the supply ports on opposing sides of the valve's body.

1. Remove all air fittings and plugs from the valve.
2. Mark the relationship of the antilock electronic controller and valve cover to the body (5). Note the position of the mounting bracket and mark the relationship of the bracket to the valve body, cover, and antilock controller. Remove and retain the four cap screws and lock washers (1) that secure the controller to the cover (15), then carefully remove the electronic controller without damaging its gasket (2).
3. While holding the exhaust cover (4), remove and discard the retaining ring (3) that secures it to the body (5).
4. Remove and discard the exhaust cover (4) along with both o-rings (6 & 7).
5. Remove and discard the valve spring (8), valve retainer (9), and the valve assembly (10) from the body (5).
6. Remove and retain the two cap screws (11) and lock washers (12) that secure the cover (15) to the body (5). Remove and retain the two bolts (13), lock washers (12), and nuts (14) that secure the cover (15) and mounting bracket to the valve body (5).
7. Separate the cover (15) and mounting bracket from the body (5), then remove and discard the sealing ring (16). Remove and retain the two cap screws and lockwashers (26) that secure the bracket to the cover (15).
8. Remove and retain the relay piston (17) and relay piston spring (19) from the body (5). NOTE: The relay piston spring, item 19 is not used in all valves.
9. Remove and discard the o-ring (18) from the relay piston (17).
10. Remove and retain the service port cap nut (20) from the cover (15), then separate and discard the cap nut o-ring (21) from the cap nut.
11. Remove and discard the quick exhaust diaphragm (22) from the cover (15).

12. Remove the quick exhaust diaphragm retaining screw (23), the diaphragm washer (24) and the diaphragm (25) from the cover (15).

### CLEANING & INSPECTION

1. Using mineral spirits or an equivalent solvent, clean and thoroughly dry all metal parts.
2. Inspect the interior and exterior of all metal parts that will be reused for severe corrosion, pitting and cracks. Superficial corrosion and/or pitting on the exterior portion of the body (5) and cover (15) is acceptable. Replace the entire valve if the interior of the body or cover exhibit signs of corrosion or pitting.
3. Inspect the bores of both the body (5) and cover (15) for deep scuffing or gouges. Replace the entire valve if either are found.
4. Make certain all air channels and exhaust passages in the valve cover (15) are clear and free of obstruction.
5. Inspect the pipe threads in the body (5). Make certain they are clean and free of thread sealant.
6. Wash all non-metallic components in a soap and water solution making certain to rinse and dry thoroughly. Inspect each non-metallic component for cracks, wear or distortion. Replace the entire valve if these conditions are found.
7. If the valve was equipped with a relay piston spring (19), inspect it for signs of corrosion, pitting and cracks. Replace as necessary.
8. Inspect all air line fittings for corrosion and replace as necessary. Make certain to remove all old thread sealant before reuse.

### ASSEMBLY

1. Prior to assembly, lubricate all o-rings, seals, and pistons, as well as body bores, using the lubricant provided with the Bendix maintenance kit.
2. Install the valve retainer (9) on the inlet and exhaust valve (10) so that the flange of the retainer (9) surrounds the rubber portion of the valve. Install the inlet and exhaust valve in the body (5).
3. Install the inlet and exhaust valve return spring (8) in the body (5).
4. Install the large and small diameter o-rings (7 & 6) in the exhaust cover (4), then install the exhaust cover in the body (5) taking care not to damage the o-rings. Hold the exhaust cover in place.
5. While depressing the exhaust cover (4), install the retaining ring (3) in the body (5). Make certain the retainer (3) is fully seated in its groove in the body.
6. If the AR-1™ valve was equipped with a relay piston return spring (19), install the spring in the body, large diameter first.

7. Using lubricant to hold them in place, install sealing ring (16) on the cover (15).
8. Install the o-ring (18) on the relay piston (17), then install the piston in the body (5).
9. After noting the relationship marks made prior to disassembly, assemble the cover (15) on the body (5) and the mounting bracket on the body (5) and secure the components together using the two cap screws (11) and two bolts (13), lock washers (12), and nuts (14). Torque the cover cap screws (11) and bolts (13) to 120-150 lb. in.
10. Install the two cap screws and lock washers (26) that secure the bracket to the cover (15) and torque them to 180-220 lb. in.
11. After noting the relationship of marks made prior to disassembly, attach the gasket (2) to the antilock controller then secure the antilock controller on the cover (15) using the four cap screws and lock washers (1). Torque the cap screws to 50-80 lb. in.
12. Install all air line fittings and plugs making certain thread sealing material does not enter the valve.
13. Install the CR-15 (AR-1™ valve with attached antilock controller) on the vehicle and perform the Operation and Leakage Tests before returning the vehicle to service.

