



Service Data

SD-13-4785

Bendix® EC-15™ AntiLock Controller Assembly

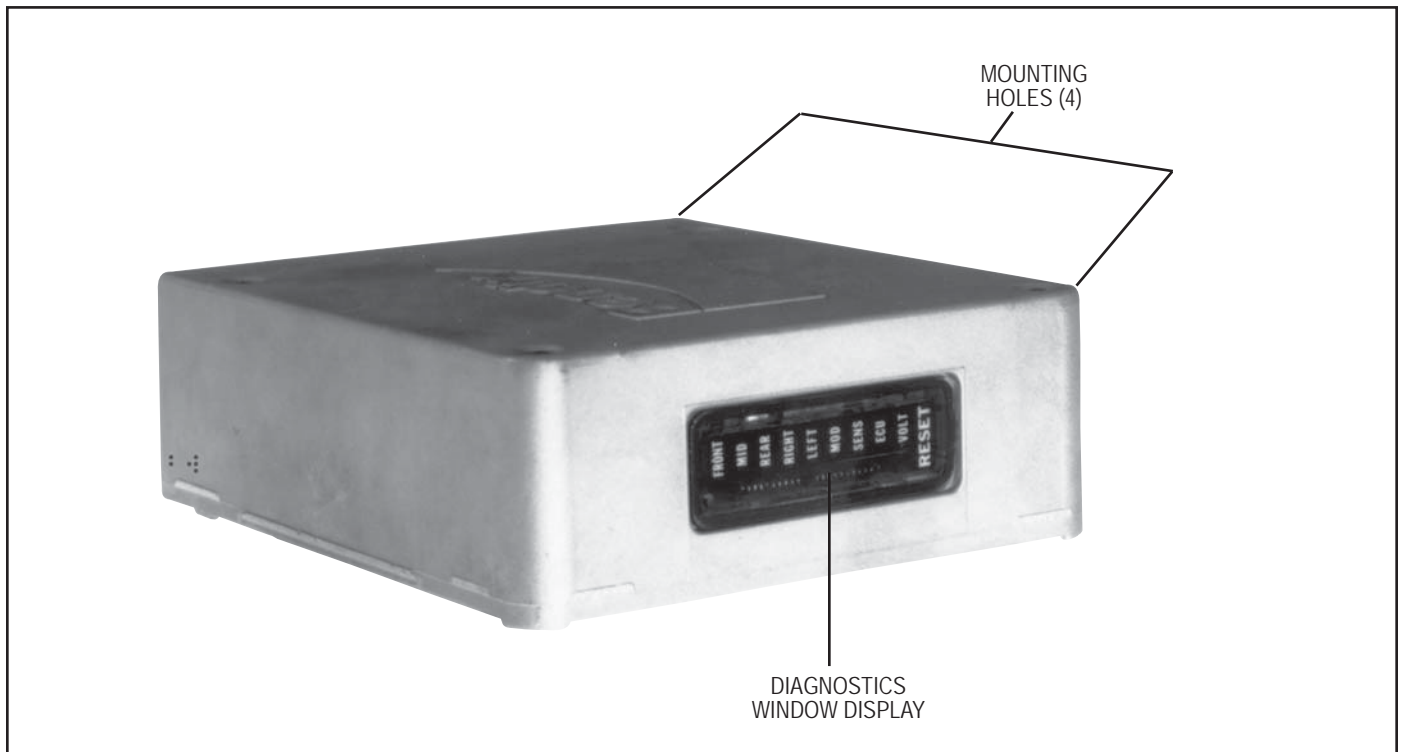

FIGURE 1 - EC-15™ ELECTRONIC CONTROLLER

DESCRIPTION

GENERAL

Bendix antilock systems utilizing the EC-15™ electronic controller assembly provide full vehicle, wheel control braking for buses, trucks, and truck tractors. By minimizing the potential of “brake lock-up” on all wheels during aggressive braking the vehicle retains a high degree of stability and steerability, and in most cases vehicle stopping distance is reduced.

In order to provide full vehicle, wheel control braking, the EC-15™ controller assembly is used in combination with the following components:

- Four, individual wheel speed sensors
- Four, air pressure modulator valves
- Antilock condition lamp (dash mounted)

PHYSICAL

The EC-15™ controller electronics, that regulate the function of the antilock system, are contained in a die cast aluminum housing and are environmentally protected. The metal housing, coupled with the design of the digital electronics, is intended to provide a high degree of protection from radio and electromagnetic interference.

A diagnostics display window with 9 light emitting diodes (LEDs) and a magnetically actuated reset switch is incorporated in the housing for troubleshooting and diagnostic purposes.

Two types of electrical connectors are currently used to connect the EC-15™ controller assembly to the antilock system components; a single, 30 pin, Packard Electric, 150 series “Metri-pack” or a pair of 14 pin, Deutsch, HID 30 series connectors.

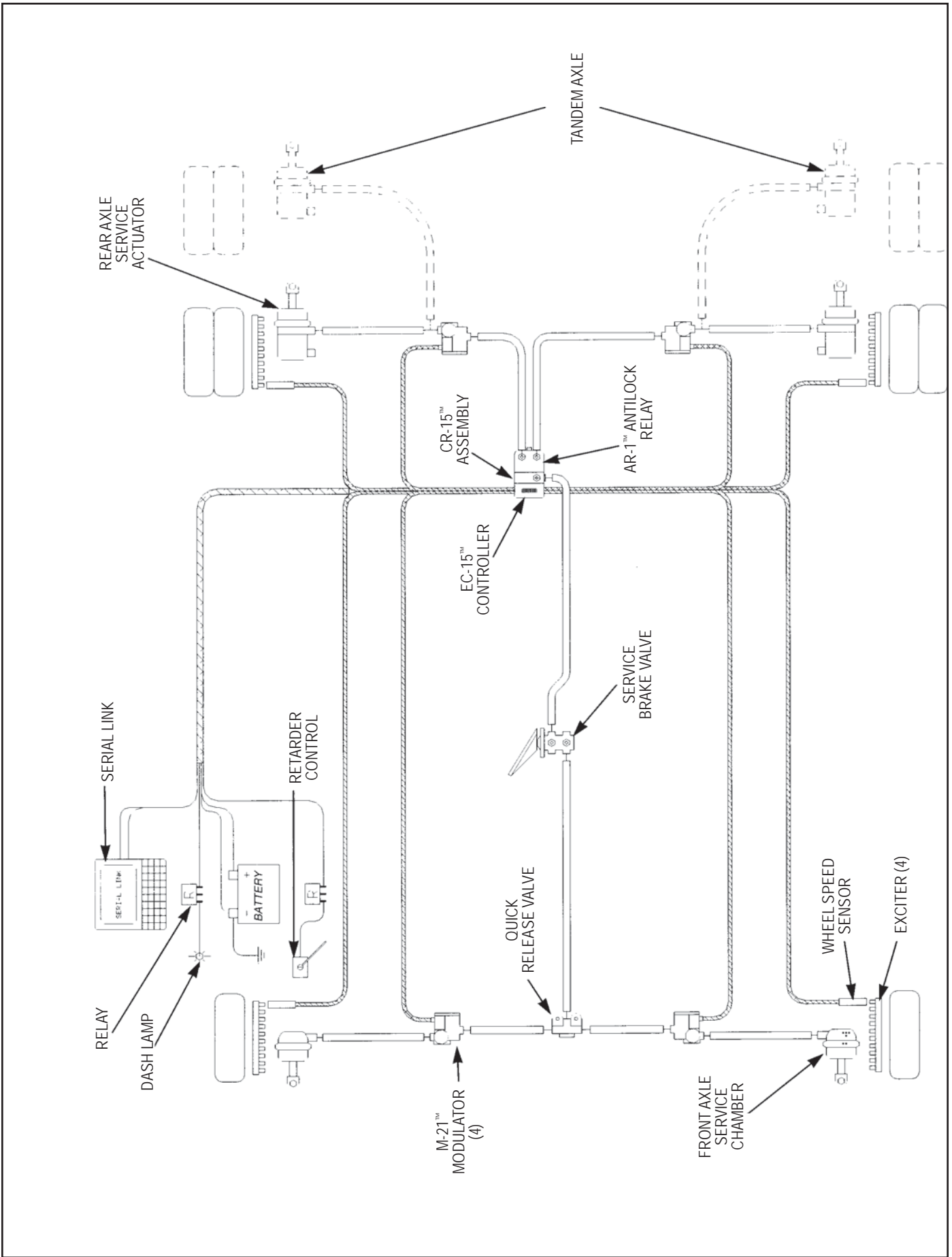

FIGURE 2 - EC-15™/CR-15™ ANTILOCK SYSTEM

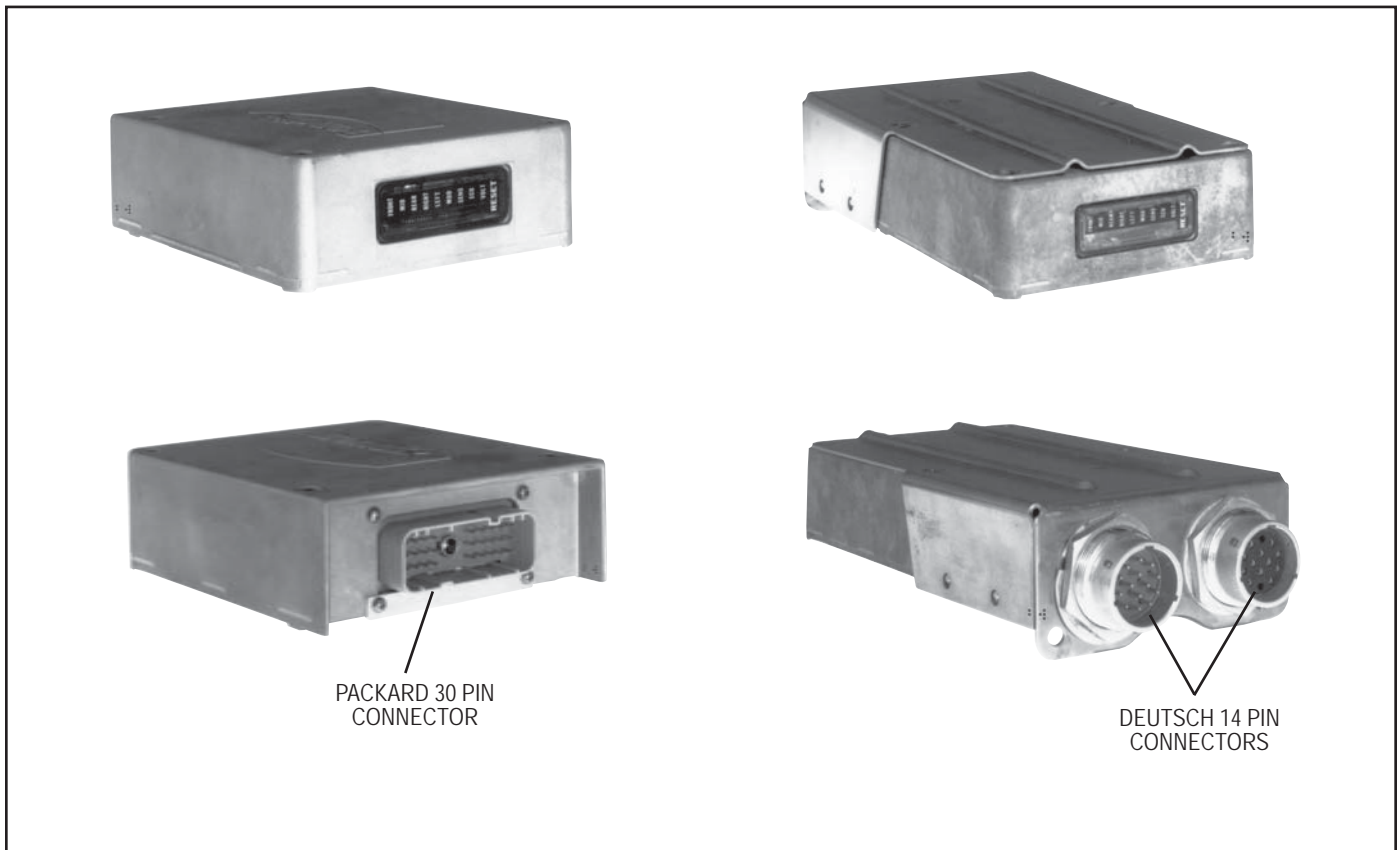

FIGURE 3 - EC-15™ CONTROLLER AND CONNECTOR STYLES

MOUNTING

The EC-15™ controller is available in two different mounting styles. One model is designed to be mounted on an antilock relay valve such as the AR-1™ valve (see Service Data Sheet SD-13-4795). The AR-1™ valve is a modified version of the R-12® relay valve. When the EC-15™ controller is mounted on an antilock relay valve the resulting assembly receives a different designation. For example when the EC-15™ antilock controller is mounted on the AR-1™ valve the resulting assembly is known as a CR-15™ antilock controller relay. The other EC-15™ controller model is intended for bracket mounting to a frame member and is not attached to an antilock relay valve.

CONTROLLER INPUTS/OUTPUTS

The EC-15™ controller receives information from several components in the antilock system and, based on these inputs, issues commands or delivers information. Some portions of the EC-15™ controller both receive and deliver commands and information.

INPUTS

Wheel speed information is provided to the EC-15™ controller via a wiring harness from individual wheel speed sensors located at or in the vehicle wheels. Working in conjunction with an exciter or tone ring, wheel speed sensors provide information to the EC-15™ controller in the form of an AC signal which varies in voltage and frequency as the speed of the wheel increases or decreases. The EC-15™ controller is designed to receive wheel speed information, from various wheel speed sensor models, at the rate of 100 pulses per wheel revolution. The EC-15™ controller is able to simultaneously receive, and individually interpret, speed signals from four wheel speed sensors.

Vehicle power is supplied to the EC-15™ controller from the ignition switch through a fuse or circuit breaker. The electrical ground for the EC-15™ controller is the vehicle chassis.

OUTPUTS

Modulators, like the Bendix® M-21™, are the means by which the EC-15™ antilock controller is able to modify driver applied air pressure to the service brakes. The modulator is an electrically controlled air valve that is located near

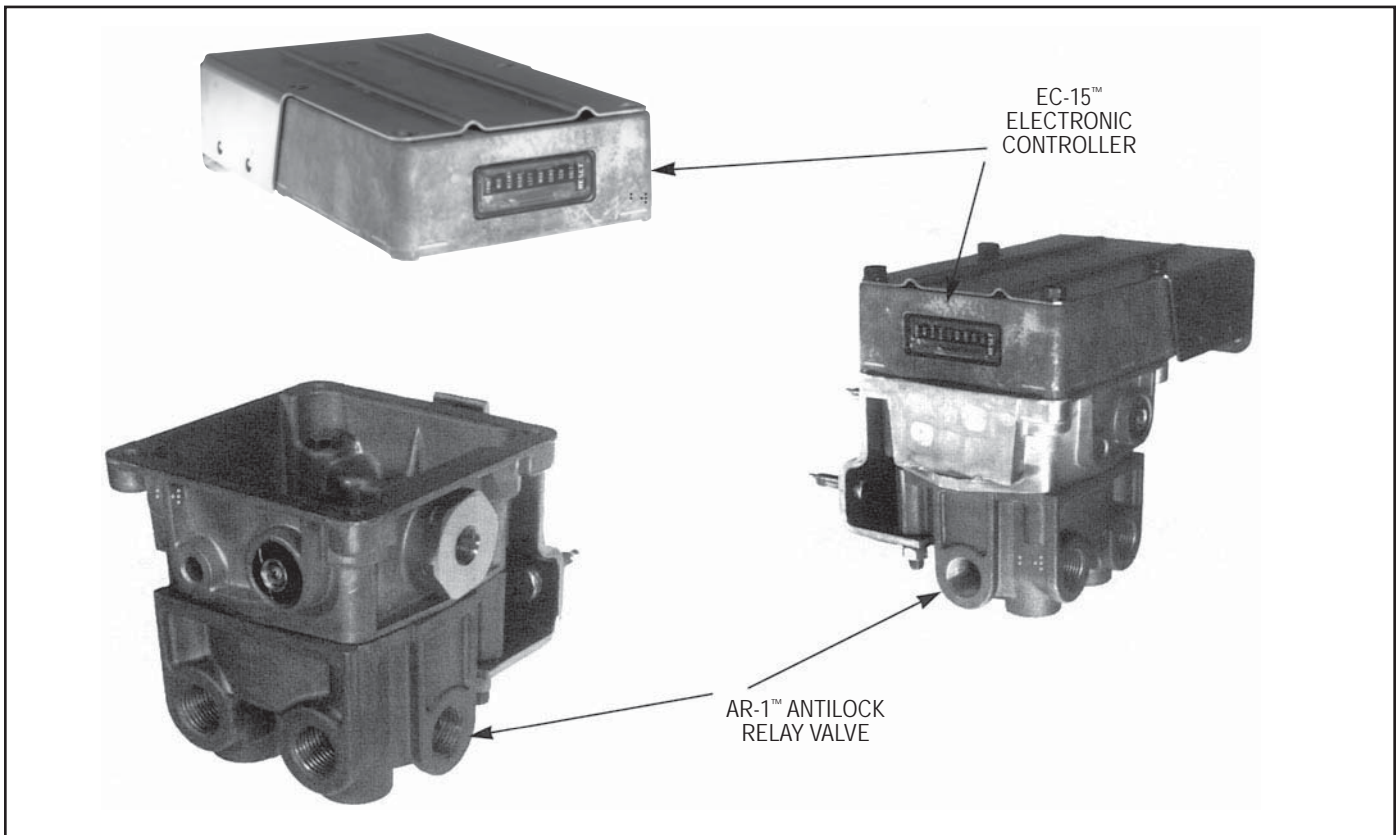

FIGURE 4 - EC-15™ CONTROLLER MOUNTED ON AN AR-1™ VALVE

the service actuator(s) it controls and is the last air valve through which air passes on its way to the brake actuator. A wiring harness connects the modulator to the EC-15™ antilock controller. Solenoid valves contained in the modulator provide the electrical interface between the EC-15™ controller electronics and the air brake system. The EC-15™ controller is able to simultaneously and independently control four individual modulator assemblies.

A dash light and its electrical relay is connected to, and controlled by, the EC-15™ controller and serves as a means of advising the driver of the condition of the antilock system. A connection to the engine or transmission retarder is provided on the EC-15™ controller which allows the EC-15™ controller to temporarily “disable” the retarder during certain modes of operation. While the EC-15™ controller is capable of this function, and connections are provided, it is not always used. Use of the retarder disable function is not essential but highly recommended for vehicles equipped with a retarder.

The data link function enables the EC-15™ controller to “report” its operating condition to a specialized, external computer in response to certain commands it receives. The EC-15™ controller data link configuration conforms to S.A.E. standard J1708 and the protocol, or coded language used, conforms to S.A.E. standard J1587. There are two connections to the EC-15™ controller devoted to the data link. While the EC-15™ controller is capable of this function, and connections are provided, it is not always used. Use of the data link is not essential for the EC-15™ controller to be functional.

OPERATION

GENERAL

The Bendix® EC-15™ antilock controller system provides individual wheel control by using a wheel speed sensor and modulator at each wheel. By monitoring the rate of deceleration during braking, and subsequently adjusting the brake application pressure at each wheel, the EC-15™ controller is able to provide improved braking between the vehicle tire and the road surface it is on, while maintaining vehicle stability.

The rear axle brakes are controlled completely independent of each other and therefore brake application pressure at an individual wheel is adjusted solely on the basis of its behavior on the road surface on which it is traveling. While each steering axle brake is under the control of an individual modulator, the EC-15™ controller does not treat these brakes totally independent of each other. The EC-15™ controller utilizes a modified individual control philosophy for the steering axle brakes. This is done in order to minimize “steering wheel pull” in the event each wheel is traveling on a different road surface (e.g.; ice close to the curb and a dry crown). Essentially the EC-15™ controller controls the braking force differences between the two brakes. The wheel on dry pavement is initially given less braking force and is brought up to optimum during the stop, while the wheel on ice attempts to maintain optimum braking during the entire stop.

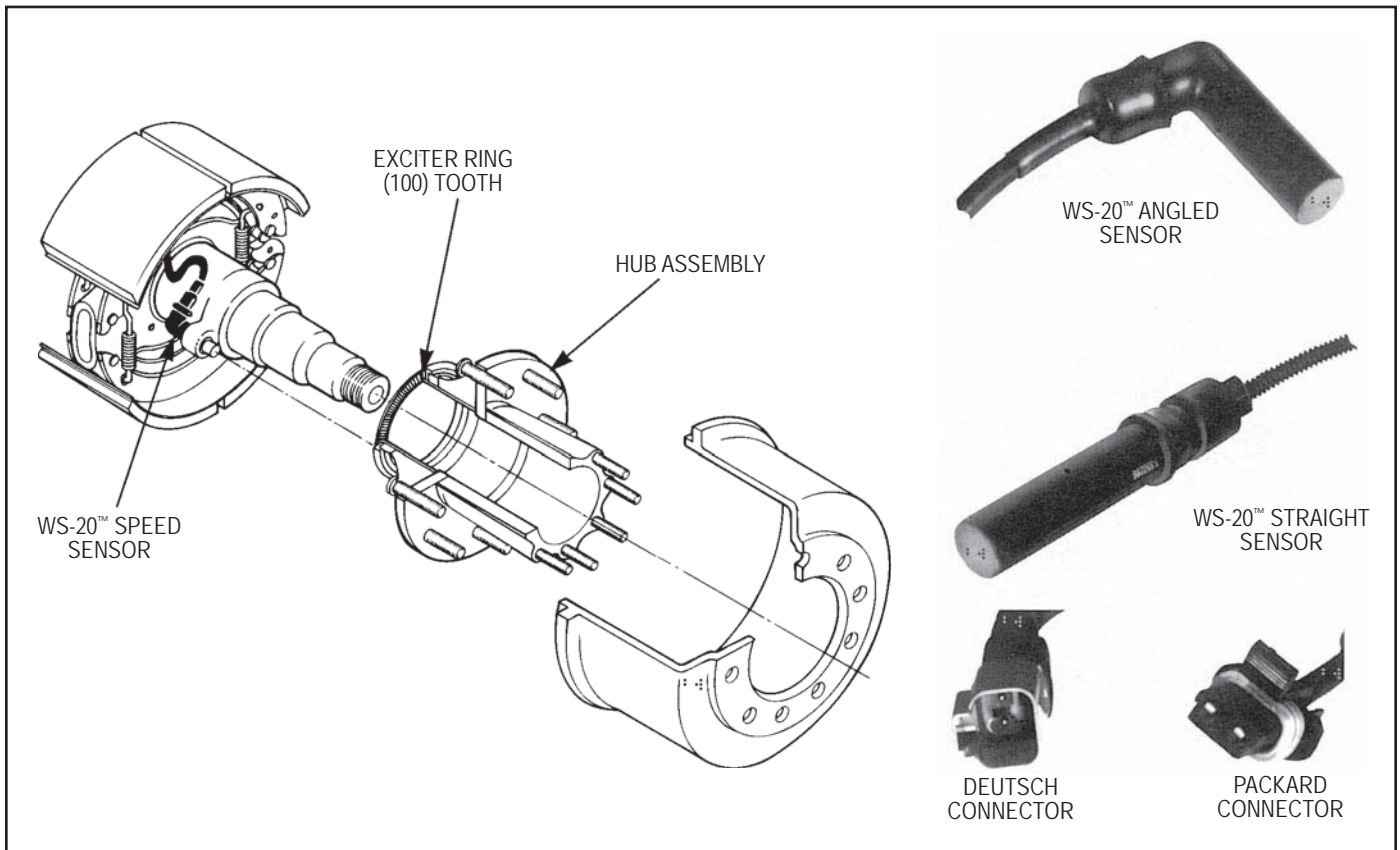

FIGURE 5 - WS-20™ WHEEL SPEED SENSORS

In the case of vehicles equipped with tandem rear axles (6x2, 6x4), the wheel speed sensors are installed at the wheels on the axle that is most likely to lose traction first. A single modulator controls both curb side brakes on the tandem, and another modulator controls both brakes on the driver's side of the tandem. With this arrangement of the speed sensors and modulators, both brakes on one side of the tandem are treated as one since they will most likely be on the same type of road surface. (Refer to figure 2)

NON-ANTILOCK BRAKE APPLICATION

During normal braking, air pressure from the brake valve enters the control port of the service relay valve (either an antilock or standard relay). The service relay delivers air to, and through, the antilock modulator located near the braked wheel, and into the brake actuator. The service brakes are thus applied. If the wheel sensors do not detect an impending wheel lock up, the EC-15™ controller does not initiate any corrective action and the vehicle comes to a stop in a normal fashion.

ANTILOCK CONTROLLED BRAKE APPLICATION SYSTEM FULLY OPERATIONAL

If a service brake application is made and the wheel speed sensors detect an impending wheel lockup, the EC-15™ controller will immediately begin modification of the brake application using the antilock modulator(s) at the affected wheel(s).

Solenoid valves contained in the modulator are energized and de-energized by the EC-15™ controller in order to modify the brake application. When a solenoid coil is energized its shuttle moves, and depending upon the function of the specific solenoid, it either opens or closes, thereby causing the exhaust or reapplication of air pressure to the brake actuator. The solenoids in each modulator are controlled independently by the EC-15™ controller. By opening and closing the solenoid valves in the appropriate modulator, the EC-15™ controller is actually simulating what the driver does when he "pumps the brakes". It must be remembered however that unlike the driver, the EC-15™ controller is able to "pump" each brake on the vehicle independently and with far greater speed and accuracy.

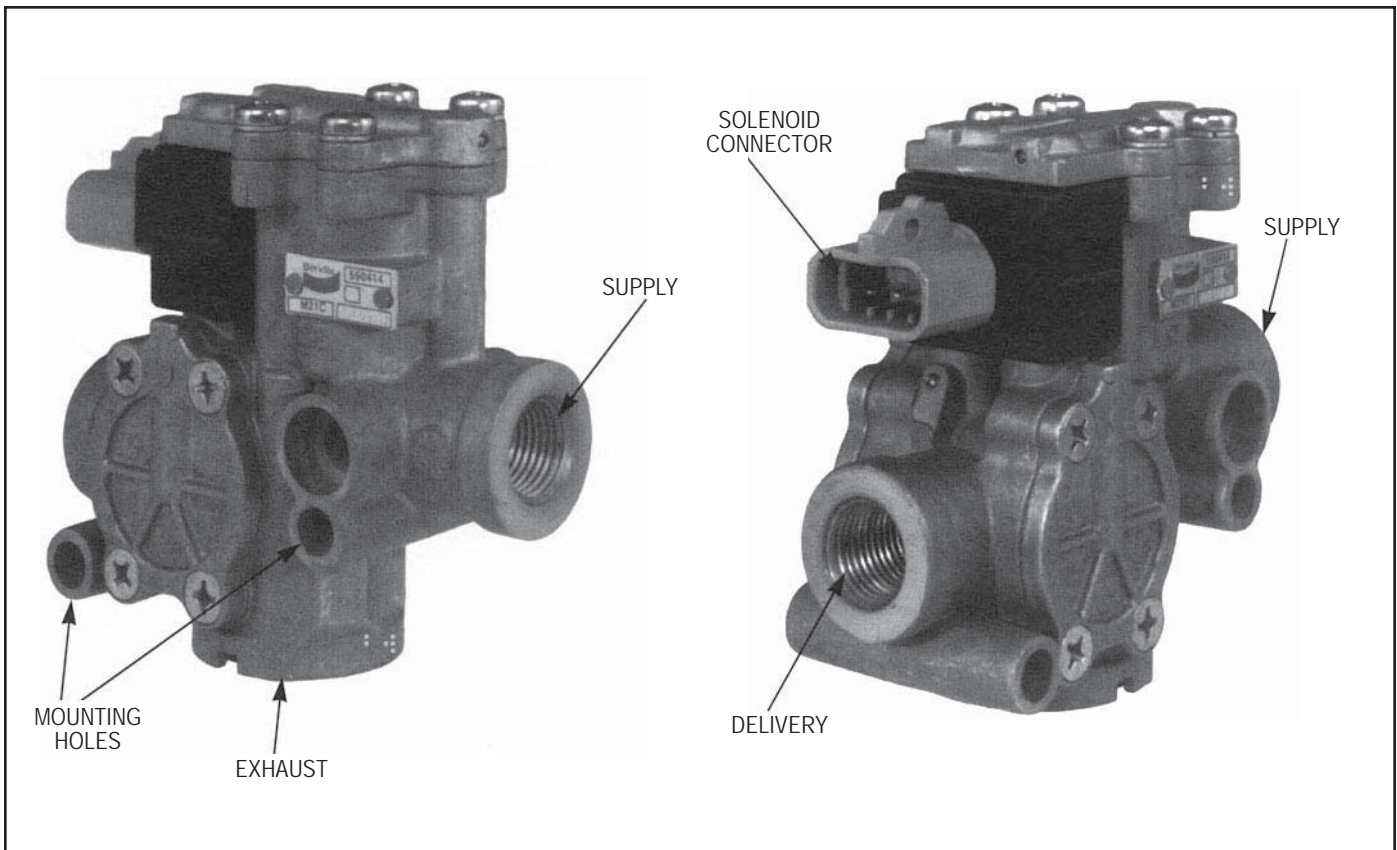

FIGURE 5 - M-21™ MODULATOR

ANTILOCK SYSTEM OPERATION - COMPONENT FAILURE

The Bendix® EC-15™ controller handles equipment failure using a conservative fail-safe philosophy. Any single electrical failure of a component devoted to antilock braking, results in simultaneous illumination of the antilock condition lamp on the dash, a disabling of all or part of the antilock system, and reversion to standard braking on wheels no longer under the control of antilock. When coping with wheel equipment (modulator or wheel speed sensor/exciter) failure, the EC-15™ controller divides and separates the brakes diagonally. For example; if the modulator at the right front wheel has a broken wire lead, the EC-15™ controller disables the antilock function for **BOTH the right front and left rear wheels**. The antilock will continue to function on the left front and right rear wheels and will remain under the control of the EC-15™ controller. (Note: Right and left, front and rear are determined from the driver's seat. Left front is therefore the corner closest to the driver). Depending upon the type of failure and its position of occurrence the EC-15™ controller either disables all, or only a portion, of the antilock system. A power or controller failure, for instance, will result in complete disabling of the antilock system and reversion to standard braking on all wheels. Two or more failures, regardless of their position of occurrence, will also result in the disabling of the entire system. With the failed component approach described, the vehicle will retain improved braking stability after a

single failure. It should be remembered that the driver will be advised of the degraded antilock operation via the dash lamp and that standard air braking will still be available on those brakes where the antilock has been disabled by the EC-15™ controller.

ANTILOCK WIRING

The wires that carry information and power into and out of the EC-15™ controller are generally grouped and terminate at a connector. The wire groups or wire harnesses along with the connectors are most often specified and or supplied by the vehicle manufacturer. Two examples of the connectors used on the EC-15™ controller are illustrated in figures 7 & 8. The wiring harnesses and connectors are weather proof and the wires that enter the connector are sealed to the connector. The wire gauge used in the wire harnesses is specific to the task performed.

When diagnosing wiring in the antilock system the following general rules apply and should be followed where applicable:

1. It is generally advisable to replace a wire harness rather than repair individual wires in the harness. If a splice repair must be made, it is important that the splice be properly soldered with a rosin flux (not acid based flux) and made water proof.

2. Do not pierce wire insulation when testing. Check for power, ground or continuity by disconnecting the connector and testing the individual pins or sockets in the connector.
3. Always check the vehicle hand book for wire and connector identification. Individual wire identification will differ depending upon the type of connectors in use, the vehicle manufacturer, and the system features in use.
4. While the retarder disable and serial link connections (3 total) are present on all EC-15™ controllers they are not always used.
4. **If the work is being performed on the vehicle's air brake system, or any auxiliary pressurized air systems, make certain to drain the air pressure from all reservoirs before beginning ANY work on the vehicle. If the vehicle is equipped with an AD-IS® air dryer system or a dryer reservoir module, be sure to drain the purge reservoir.**
5. **Following the vehicle manufacturer's recommended procedures, deactivate the electrical system in a manner that safely removes all electrical power from the vehicle.**
6. **Never exceed manufacturer's recommended pressures.**
7. **Never connect or disconnect a hose or line containing pressure; it may whip. Never remove a component or plug unless you are certain all system pressure has been depleted.**
8. **Use only genuine Bendix® replacement parts, components and kits. Replacement hardware, tubing, hose, fittings, etc. must be of equivalent size, type and strength as original equipment and be designed specifically for such applications and systems.**
9. **Components with stripped threads or damaged parts should be replaced rather than repaired. Do not attempt repairs requiring machining or welding unless specifically stated and approved by the vehicle and component manufacturer.**
10. **Prior to returning the vehicle to service, make certain all components and systems are restored to their proper operating condition.**
11. **For vehicles with Antilock Traction Control (ATC), the ATC function must be disabled (ATC indicator lamp should be ON) prior to performing any vehicle maintenance where one or more wheels on a drive axle are lifted off the ground and moving.**

PREVENTATIVE MAINTENANCE

Every 3 months; 25,000 miles; or 900 operating hours,

1. Check all wiring and connectors to ensure they are secure and free from visible damage.
2. Although the EC-15™ controller incorporates a self check diagnostics, the LED display should be inspected to ensure that they are functional. With the vehicle ignition on, a magnet (800 gauss; capable of picking up 3 ounces) held to the LED reset switch should cause all of the LED's to illuminate. If one or more of the LED's DO NOT ILLUMINATE and the antilock condition lamp on the dash indicates the system is functioning properly, the non-illuminated LED(s) should be noted for future reference. Although the diagnostic capabilities will be limited, the system will continue to function as designed.
3. Road test the vehicle by making antilock stop from a vehicle speed of 20 miles per hour. When an antilock stop is made, the modulator solenoids pulsate and an audible burst of air can be heard from outside of the cab. The wheels should not enter a prolonged "lock" condition.

WARNING! PLEASE READ AND FOLLOW THESE INSTRUCTIONS TO AVOID PERSONAL INJURY OR DEATH:

When working on or around a vehicle, the following general precautions should be observed at all times.

1. **Park the vehicle on a level surface, apply the parking brakes, and always block the wheels. Always wear safety glasses.**
2. **Stop the engine and remove ignition key when working under or around the vehicle. When working in the engine compartment, the engine should be shut off and the ignition key should be removed. Where circumstances require that the engine be in operation, EXTREME CAUTION should be used to prevent personal injury resulting from contact with moving, rotating, leaking, heated or electrically charged components.**
3. **Do not attempt to install, remove, disassemble or assemble a component until you have read and thoroughly understand the recommended procedures. Use only the proper tools and observe all precautions pertaining to use of those tools.**

REMOVING THE EC-15™ CONTROLLER ASSEMBLY

EC-15™ CONTROLLER MOUNTED ON ANTILOCK RELAY VALVE

1. Identify and remove all air lines connected to the unit.
2. Disconnect the electrical connector(s) from the EC-15™ controller.
3. Note and mark the mounting position of the controller/relay valve assembly on the vehicle. Loosen, remove and save the nuts on the mounting hardware that attaches the controller relay assembly bracket to the vehicle. Remove the relay valve and EC-15™ controller assembly from the vehicle.
4. Remove as much contamination as possible from the exterior of the assembly making sure to keep the contamination away from the open ports.
5. Note and mark the position of the EC-15™ controller relative to the antilock relay valve. Remove and retain the four cap screws that secure the EC-15™ controller to the antilock relay valve. Carefully separate the EC-15™ controller from the antilock relay valve making certain

DEUTSCH CONNECTORS

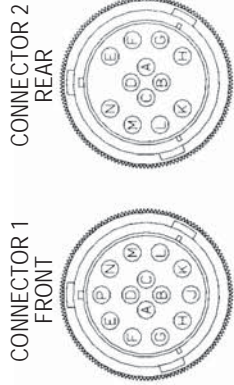

TERMINAL TERMINAL CONNECTION

TERMINAL	TERMINAL CONNECTION
1J	POWER
1K	DASH LAMP (RELAY)
1P	GROUND
1N	LEFT FRONT MODULATOR EXHAUST
1E	LEFT FRONT MODULATOR HOLD
1M	LEFT FRONT MODULATOR SOURCE
1F	LEFT FRONT SPEED SIGNAL
1G	LEFT FRONT SPEED SIGNAL RETURN
1B	RETARDER DISABLE
1C	RIGHT FRONT MODULATOR EXHAUST
1A	RIGHT FRONT MODULATOR HOLD
1D	RIGHT FRONT MODULATOR SOURCE
1H	RIGHT FRONT SPEED SIGNAL
1L	RIGHT FRONT SPEED SIGNAL RETURN
2K	LEFT REAR SPEED SIGNAL
2G	LEFT REAR SPEED SIGNAL RETURN
2A	LEFT REAR MODULATOR EXHAUST
2C	LEFT REAR MODULATOR HOLD
2D	LEFT REAR MODULATOR SOURCE
2M	RIGHT REAR SPEED SIGNAL
2L	RIGHT REAR SPEED SIGNAL RETURN
2E	RIGHT REAR MODULATOR EXHAUST
2N	RIGHT REAR MODULATOR HOLD
2F	RIGHT REAR MODULATOR SOURCE
2B	SERIAL A
2H	SERIAL B

VEHICLE RIGHT FRONT

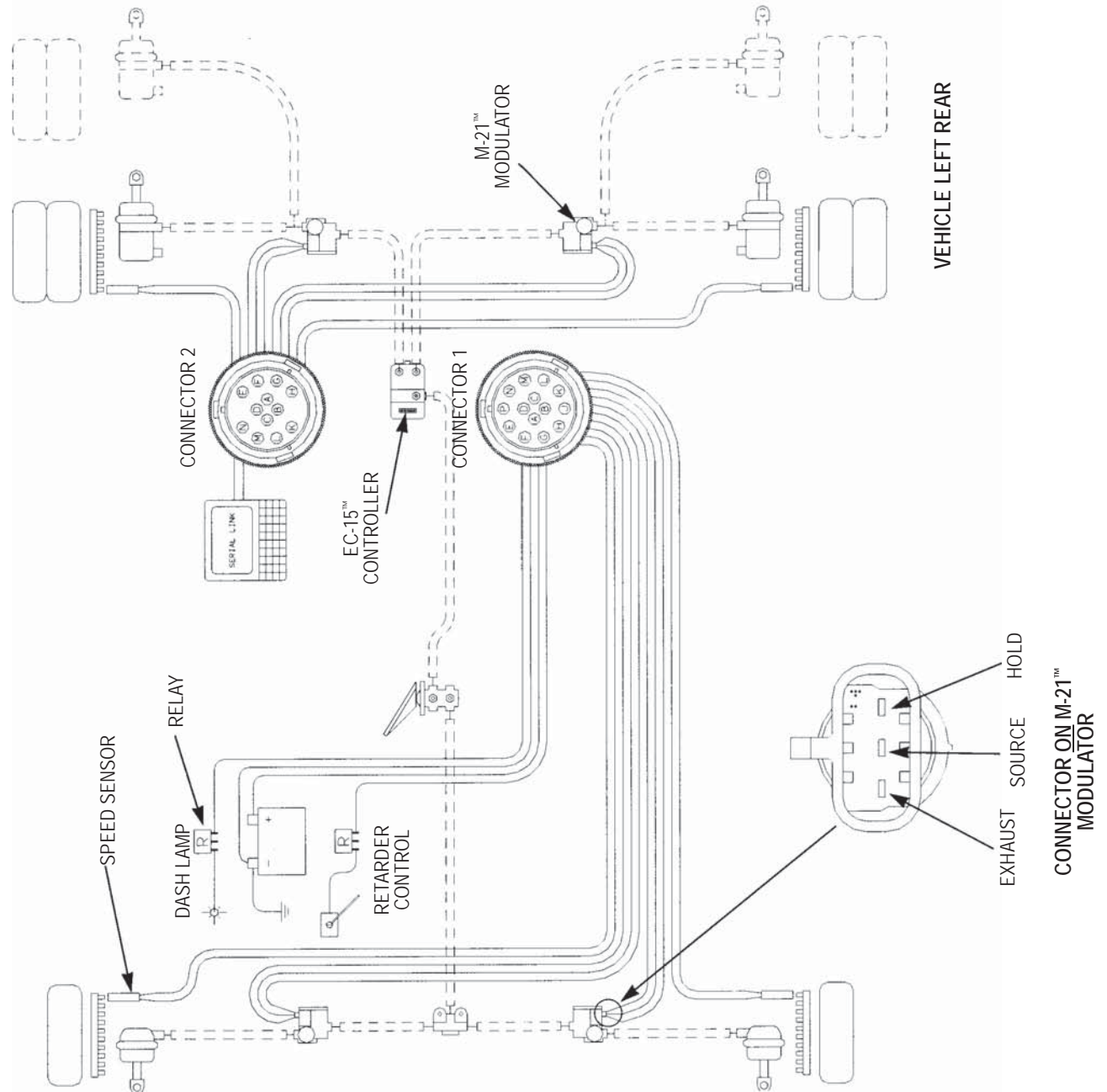

VEHICLE LEFT REAR

CONNECTOR ON M-21™
MODULATOR

FIGURE 7 - WIRING SCHEMATIC FOR EC-15™ CONTROLLER WITH DEUTSCH CONNECTORS

PACKARD CONNECTOR

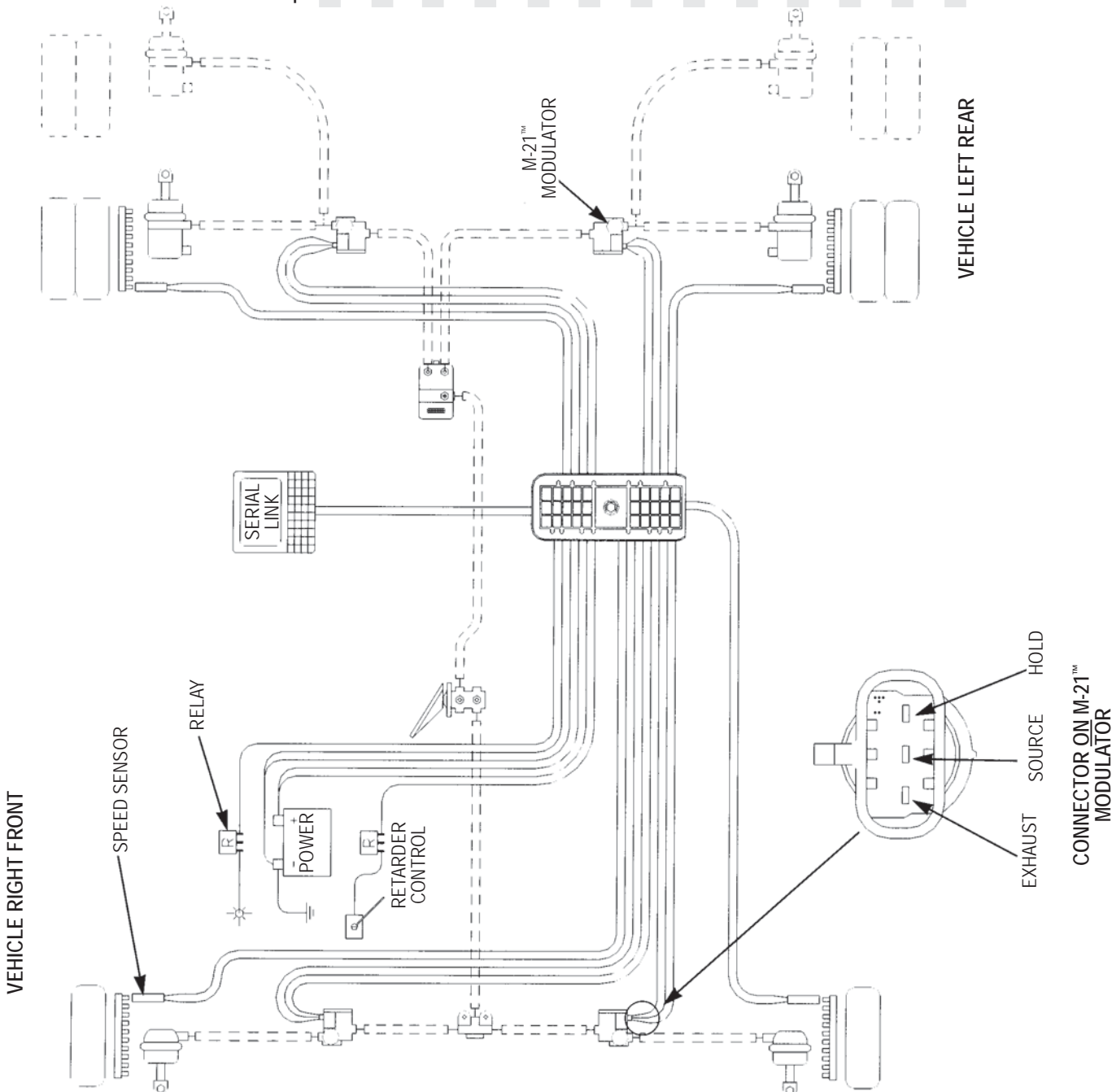
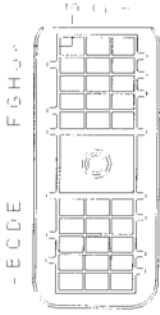

TERMINAL TERMINAL CONNECTION

TERMINAL	TERMINAL CONNECTION
1K & 2K	POWER
3F	DASH LAMP (RELAY)
1A & 2A	GROUND
2F	LEFT FRONT MODULATOR EXHAUST
2G	LEFT FRONT MODULATOR HOLD
1G	LEFT FRONT MODULATOR SOURCE
3J	LEFT FRONT SPEED SIGNAL
3H	LEFT FRONT SPEED SIGNAL RETURN
3G	RETARDER DISABLE
1H	RIGHT FRONT MODULATOR EXHAUST
1J	RIGHT FRONT MODULATOR HOLD
1F	RIGHT FRONT MODULATOR SOURCE
2H	RIGHT FRONT SPEED SIGNAL
3K	RIGHT FRONT SPEED SIGNAL RETURN
3E	LEFT REAR SPEED SIGNAL
2C	LEFT REAR SPEED SIGNAL RETURN
1B	LEFT REAR MODULATOR EXHAUST
1C	LEFT REAR MODULATOR HOLD
1D	LEFT REAR MODULATOR SOURCE
3D	RIGHT REAR SPEED SIGNAL
3C	RIGHT REAR SPEED SIGNAL RETURN
2D	RIGHT REAR MODULATOR EXHAUST
2E	RIGHT REAR MODULATOR HOLD
1E	RIGHT REAR MODULATOR SOURCE
3A	SERIAL A
3B	SERIAL B
2B	NOT USED
2J	NOT USED

FIGURE 9 - WIRING SCHEMATIC FOR EC-15™ CONTROLLER WITH PACKARD CONNECTOR

not to damage the gasket between the two components. Peel the gasket from the EC-15™ controller or antilock relay valve and retain for reuse. Note: Use a new gasket if damaged during removal or if a new gasket is immediately available.

BRACKET MOUNTED EC-15™ CONTROLLER

1. Disconnect the electrical connector(s) from the EC-15™ controller.
2. Note and mark the mounting position of the EC-15™ controller on the vehicle. Loosen, remove and save the nuts on the mounting hardware that attaches the EC-15™ controller bracket to the vehicle. Remove the EC-15™ controller and bracket from the vehicle.
3. Remove and retain the four cap screws that secure the EC-15™ controller to the bracket. Separate the EC-15™ controller from the bracket.

INSTALLING THE EC-15™ CONTROLLER ASSEMBLY

EC-15™ CONTROLLER MOUNTED ON ANTILOCK RELAY VALVE

1. After noting the relationship of the positioning marks made prior to disassembly, position the gasket on the EC-15™ controller then secure the EC-15™ controller to the antilock relay valve using the four cap screws. Torque the cap screws to 50-80 lbs. in.
2. Mount the assembled EC-15™ controller and antilock relay valve on the vehicle and orient it in the position marked prior to removal.
3. Reconnect all air lines to the assembly.
4. Reconnect the electrical connector(s) to the EC-15™ controller.
5. Test the antilock relay valve for operation and leakage prior to placing the vehicle in service.
6. Perform the “Initial Start-up Procedure” in the TROUBLESHOOTING section to assure proper antilock system operation.

BRACKET MOUNTED EC-15™ CONTROLLER

1. Secure the EC-15™ controller to its bracket using the four cap screws. Torque the cap screws to 50-80 lbs. in.
2. After noting the positioning marks, mount the EC-15™ controller on the vehicle using the mounting hardware retained during removal.
3. Connect the electrical connector(s) to the EC-15™ controller.

4. Perform the “Initial Start-up Procedure” in the TROUBLESHOOTING section to assure proper antilock system operation.

DIAGNOSING AND LOCATING A SYSTEM PROBLEM

GENERAL

The EC-15™ controller contains self test and diagnostic circuitry that continuously checks for proper operation of the entire antilock system including wiring continuity. A dash lamp, controlled by the EC-15™ controller, advises the driver of the condition of the entire antilock system. The condition of specific antilock components is provided to the mechanic by a series of labeled, light emitting diodes (LED's) displayed through a “window” in the EC-15™ controller housing. No special tools or equipment are needed to read or interpret the EC-15™ controller diagnostics window. It should be noted that the EC-15™ controller diagnostics display is separate from the antilock condition lamp on the dash. With this separation, the driver is aware of any problems that occur but is not confused by the diagnostic information. A special feature of the EC-15™ controller is the failure latching and diagnostic system. Intermittent problems, particularly in the wheel speed sensing area can be difficult to diagnose. When the controller senses an erroneous condition, whether in the controller electronics, the modulator or wheel speed sensing areas, it stores the condition in non-volatile memory, disables the antilock function, illuminates the dash mounted antilock condition lamp and the appropriate diagnostic LEDs on the EC-15™ controller.

The failure condition is truly stored and is not cleared by loss of power to the EC-15™ controller. The LEDs will re-light when power is restored and remain illuminated until the failure is corrected. After the actual problem is corrected, maintenance personnel can clear or reset the EC-15™ controller diagnostics by passing a small magnet over the RESET point in the diagnostics window.

DIAGNOSTIC LEDs

There are nine LEDs plus a magnetically actuated reset switch in the EC-15™ controller diagnostic window. The first five LEDs locate a problem to a specific area of the vehicle while the last four indicate the problem component or its wiring. The LEDs are software driven and are either ON or OFF depending upon their monitor function. (Note: Right and left, front and rear are determined from the driver's seat. Left front is therefore the corner closest to the driver.)

LED o FRONT	Red LED
LED o MID	Red LED (SEE NOTE BELOW)
LED o REAR	Red LED
LED o RIGHT	Red LED
LED o LEFT	Red LED
LED o MOD	Red LED
LED o SENS	Red LED
LED o ECU	Red LED
LED o VOLT	Green LED
III RESET	No LED

NOTE: The MID LED shown in the chart above is not used in the diagnostic process for the EC-15™ controller however it will light when a magnet is placed on the RESET switch in the diagnostic window.

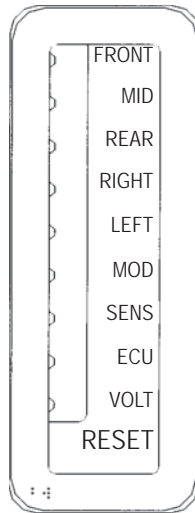

**EC-15™ CONTROLLER
DIAGNOSTIC WINDOW**

“FRONT” LED

This Red LED illuminates and latches ON in order to indicate the location of a problem component or its wiring. It will light in conjunction with either the RIGHT or LEFT LED and the MOD or SENS LED.

“MID” LED

This Red LED is not used in troubleshooting the EC-15™ controller and should light only when a magnet is held on the RESET switch.

“REAR” LED

This Red LED illuminates and latches ON in order to indicate the location of a problem component or its wiring. It will light in conjunction with either the RIGHT or LEFT LED and the MOD or SENS LED.

“RIGHT” LED

This Red LED illuminates and latches ON in order to indicate the location of a problem component or its wiring. It will light in conjunction with either the FRONT or REAR LED and the MOD or SENS LED.

“LEFT” LED

This Red LED illuminates and latches ON in order to indicate the location of a problem component or its wiring. It will light in conjunction with either the FRONT or REAR LED and the MOD or SENS LED.

“MOD” LED

This Red LED illuminates and latches ON to indicate a permanent or intermittent open or short circuit in the solenoids of one of the four modulators or the wiring connecting it to the system.

“SENS” LED

This Red LED illuminates and latches ON to indicate permanent or intermittent failure. The failures indicated are; open or shorted wheel speed sensor, open or shorted wheel speed sensor wiring, wheel speed signal not present or does not conform to design criteria.

“ECU” LED

This Red LED, when illuminated, indicates that the controller itself has failed. It is latched ON for all EC-15™ controller failures except low voltage. For voltages less than 9VDC, the LED illuminates to indicate the controller is inoperative, however when the voltage again exceeds 9VDC the LED will go OUT by itself.

“VOLT” LED

This Green LED illuminates and remains ON during vehicle operation to indicate that vehicle power is reaching the controller. If vehicle power is out of range for proper operation (below 11 vdc or above 17 vdc) this LED will flash until power is brought into range.

“RESET”

Beneath the RESET area of the window display is a magnetically sensitive switch that is used to reset the diagnostic system. The device will respond to a magnet which has strength sufficient to lift a three (3) ounce weight. Holding a magnet against the RESET will cause all LEDs to light during the time the magnet is against it.

TROUBLESHOOTING

GENERAL

While the EC-15™ controller diagnostic display locates a specific problem area, it is still necessary to confirm whether the problem resides in the component itself or the wiring. Basically the troubleshooting procedure that follows is devoted to narrowing the problem to either the wiring or a specific antilock component.

TROUBLESHOOTING TIPS

1. All troubleshooting begins by observing the antilock condition lamp on the dash. Troubleshooting should begin by first performing the “Initial Start-up Procedure” and following the directions contains in it.
2. The troubleshooting technician should record all findings and the action taken during the troubleshooting process.
3. No voltage or resistance tests are performed into the EC-15™ controller. All voltage and resistance tests are performed by beginning at the wire harness half of the connector and moving AWAY from the EC-15™ controller toward an antilock system component (modulator, wheel speed sensor, etc.)

TROUBLESHOOTING
INITIAL START-UP PROCEDURE

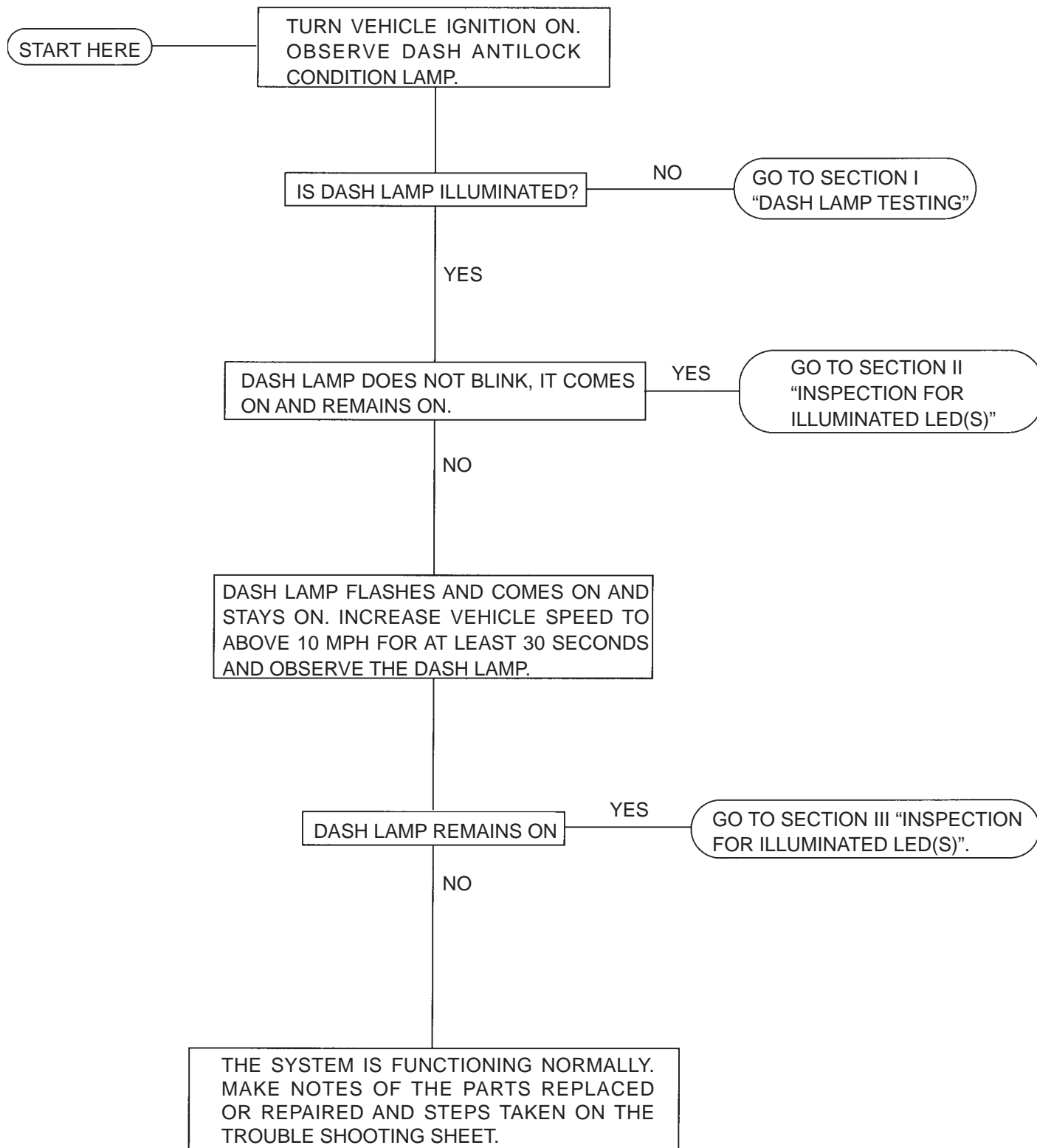

TROUBLESHOOTING

SECTION I - DASH LAMP TESTING

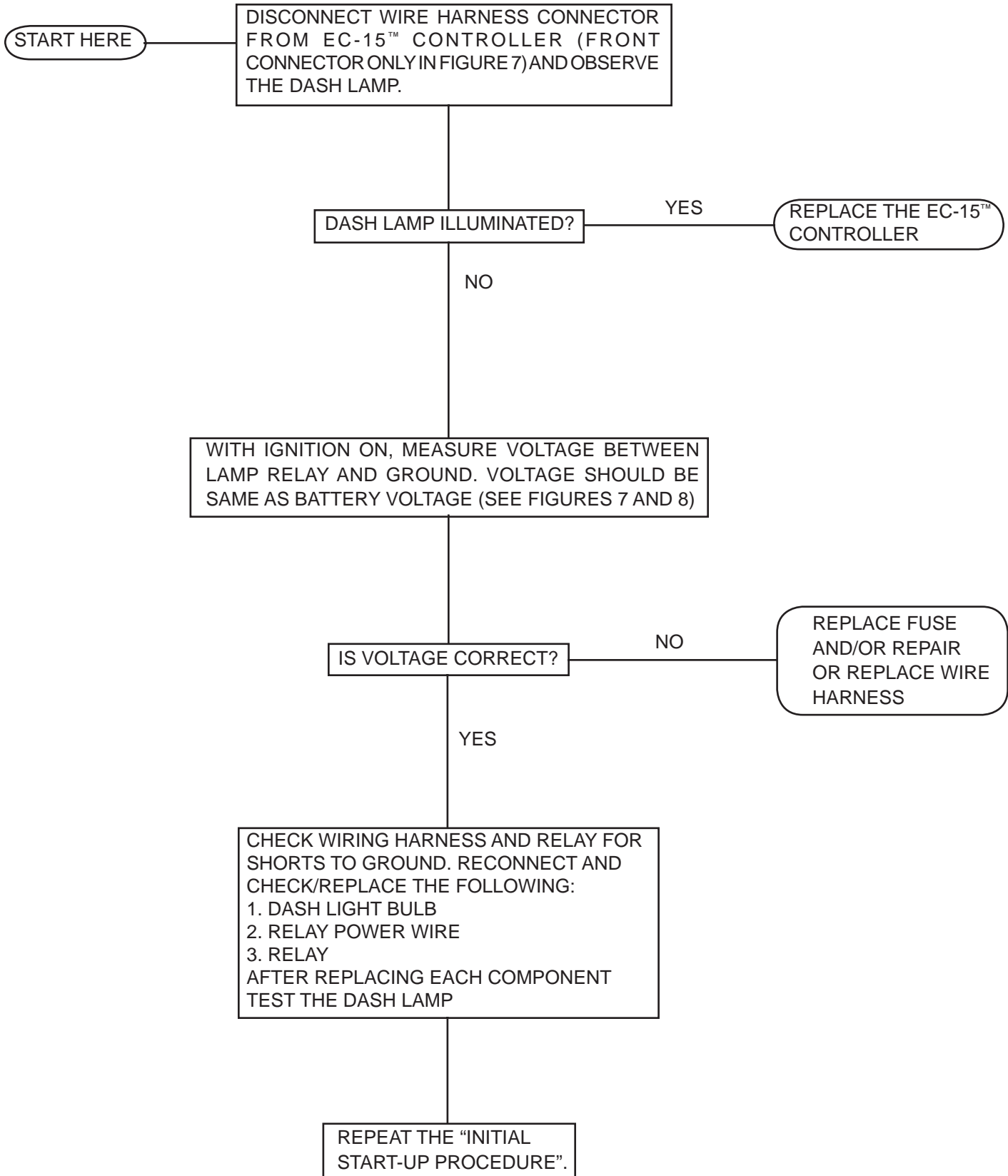

TROUBLESHOOTING

SECTION II - INSPECTION FOR ILLUMINATED LEDS

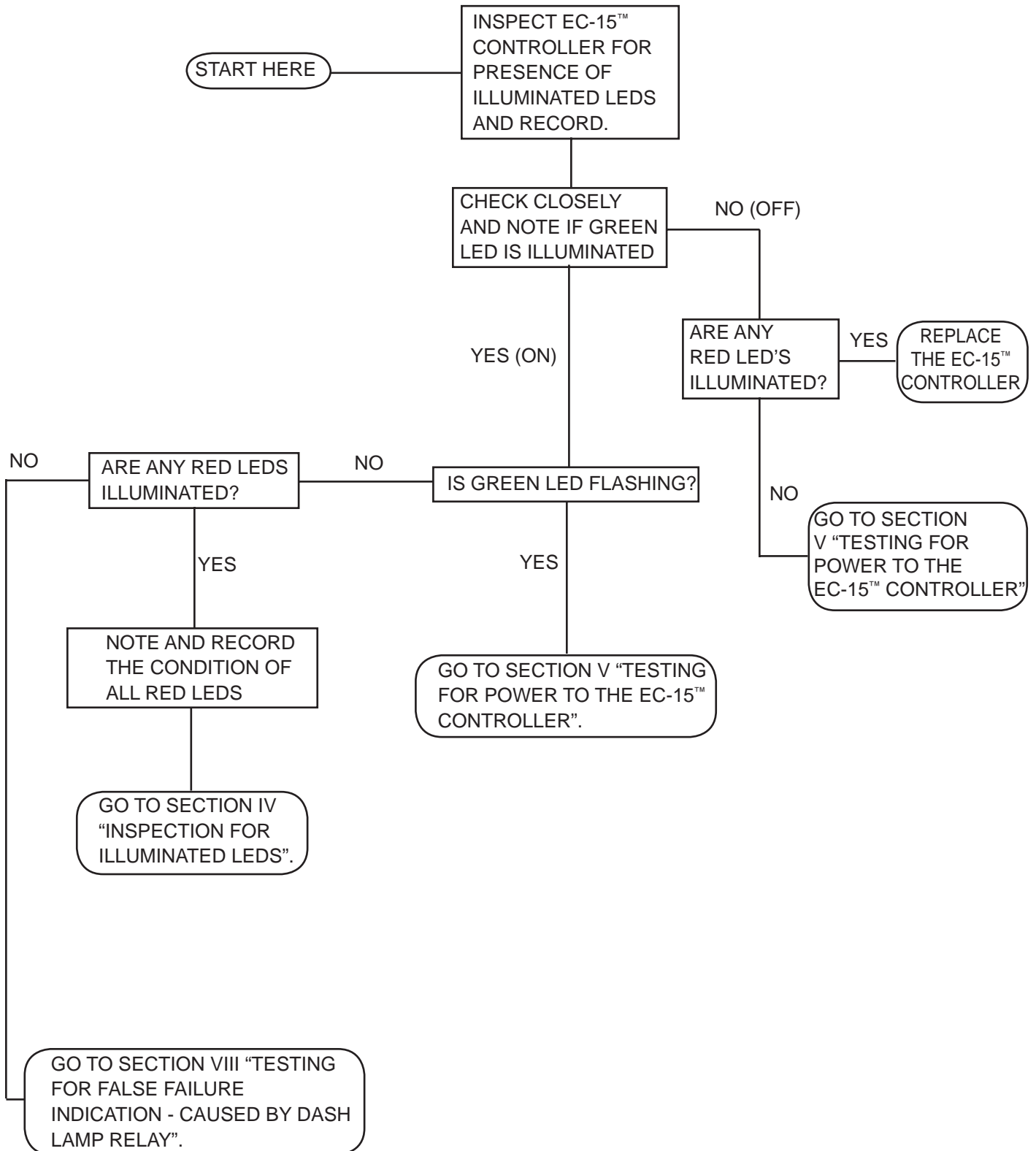

TROUBLESHOOTING

SECTION III - INSPECTION FOR ILLUMINATED LED'S

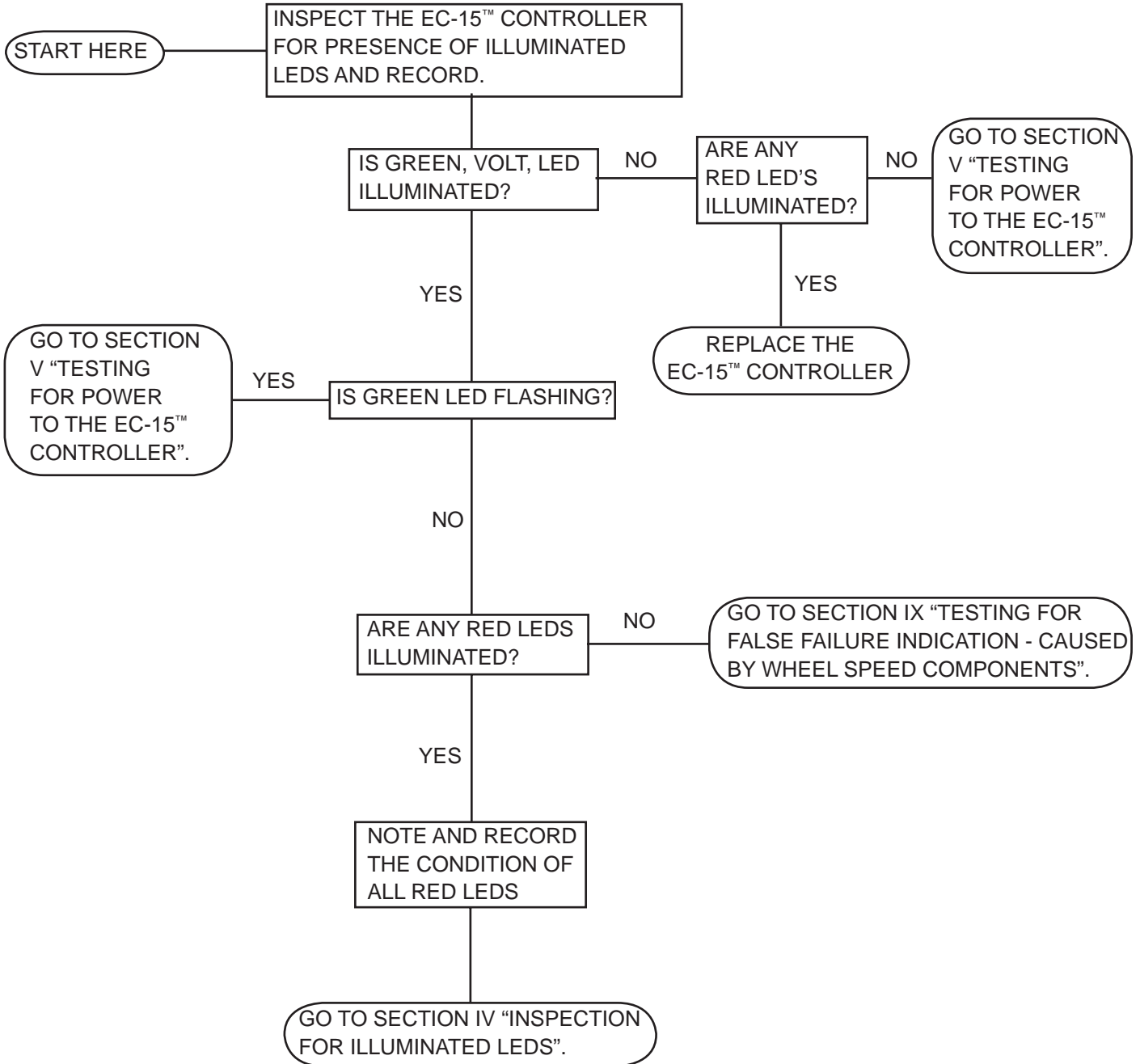

TROUBLESHOOTING

SECTION IV - INSPECTION FOR ILLUMINATED LEDS.

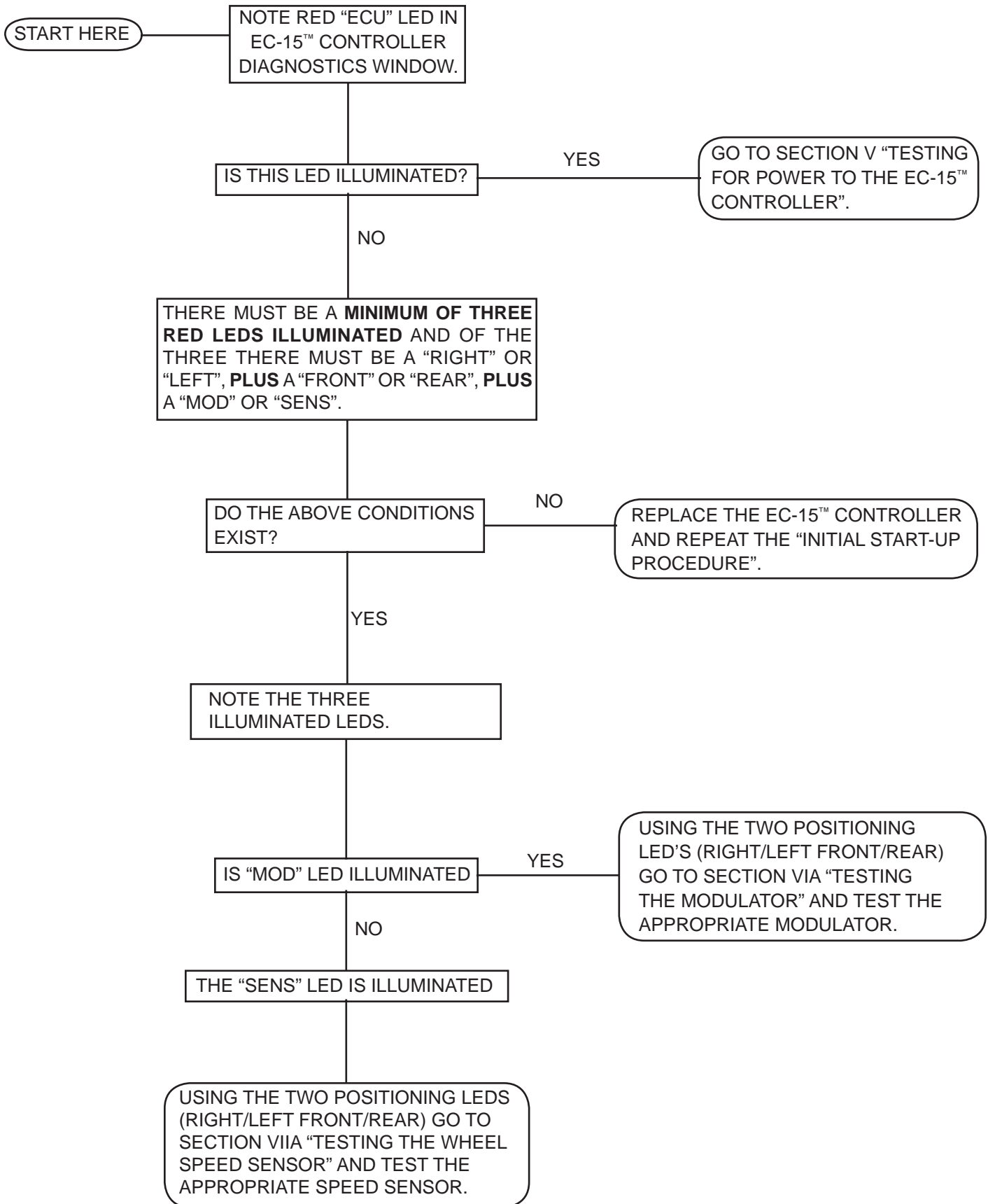

TROUBLESHOOTING

SECTION V - TESTING FOR POWER TO THE EC-15™ CONTROLLER

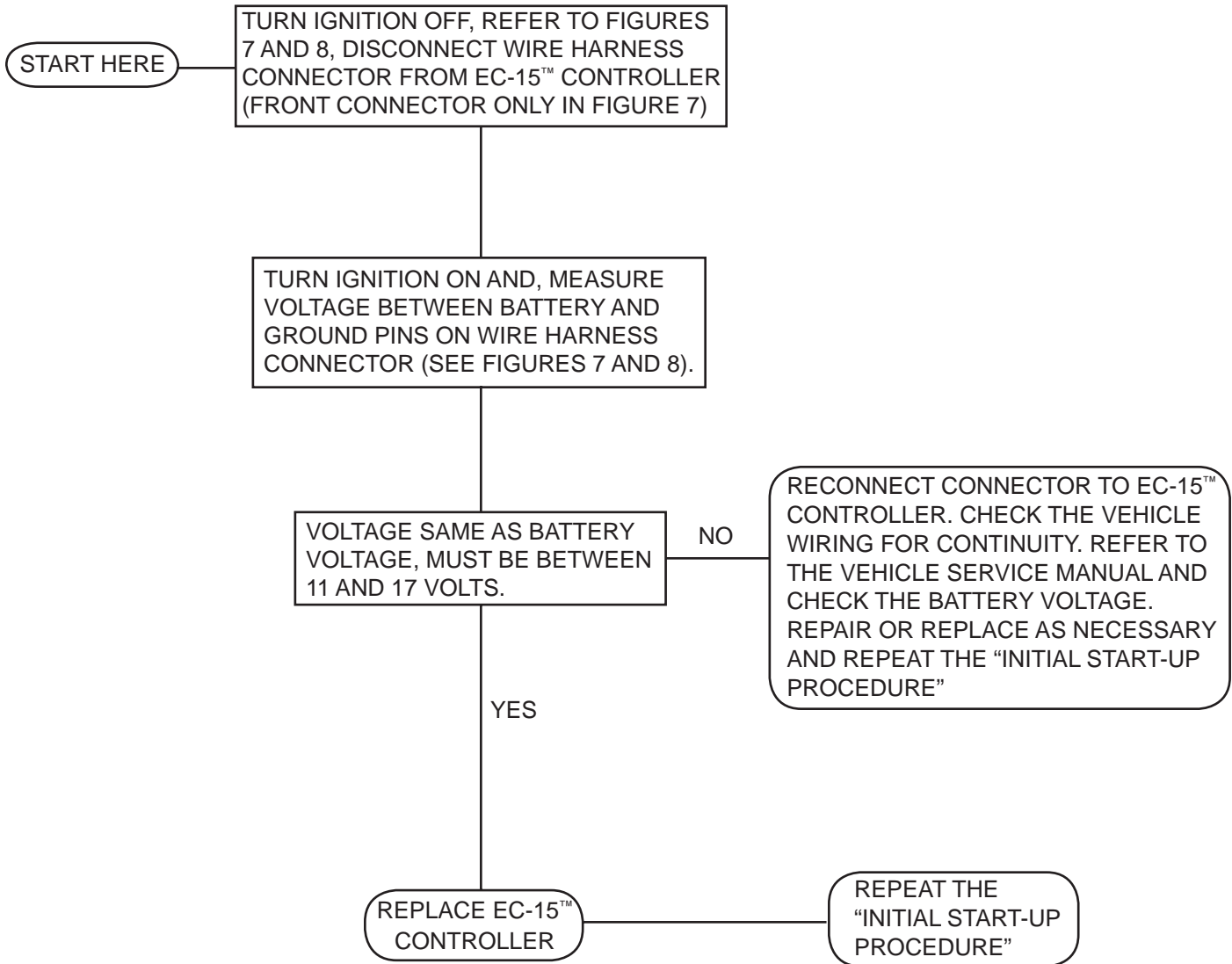

TROUBLESHOOTING

SECTION VI A - TESTING THE MODULATOR

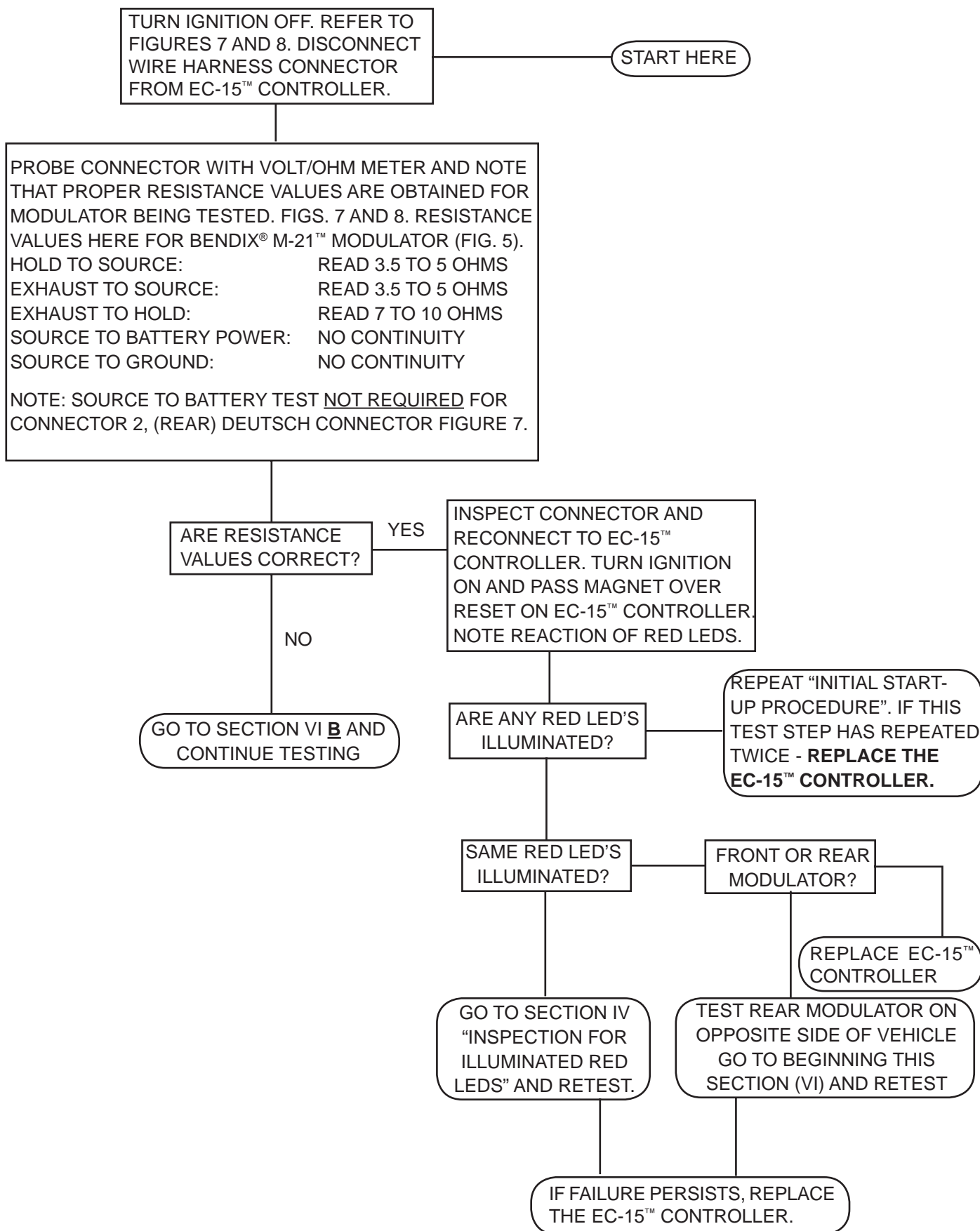

TROUBLESHOOTING

SECTION VI B - TESTING THE MODULATOR

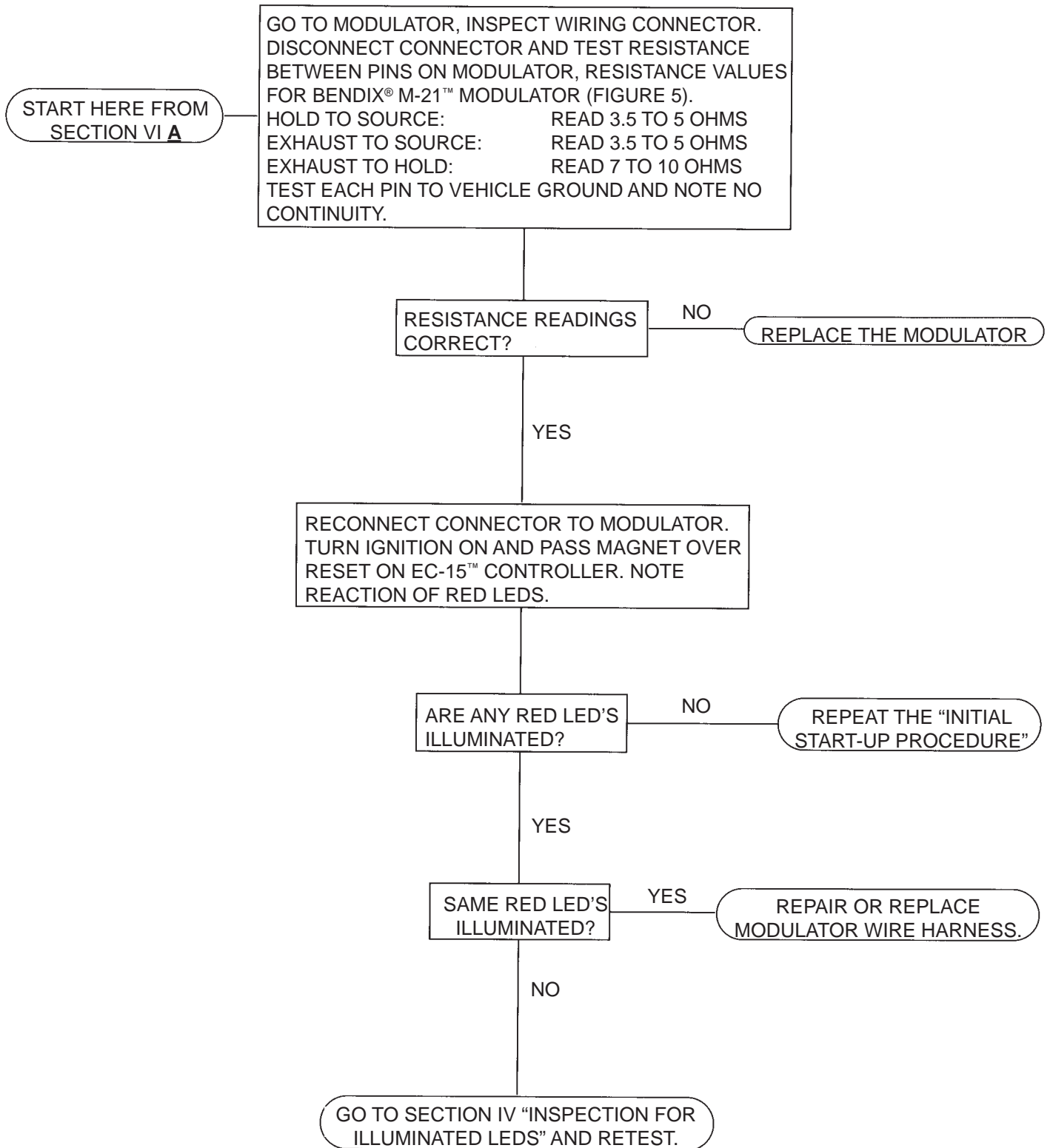

TROUBLESHOOTING

SECTION VII PART A - TESTING THE WHEEL SPEED SENSOR

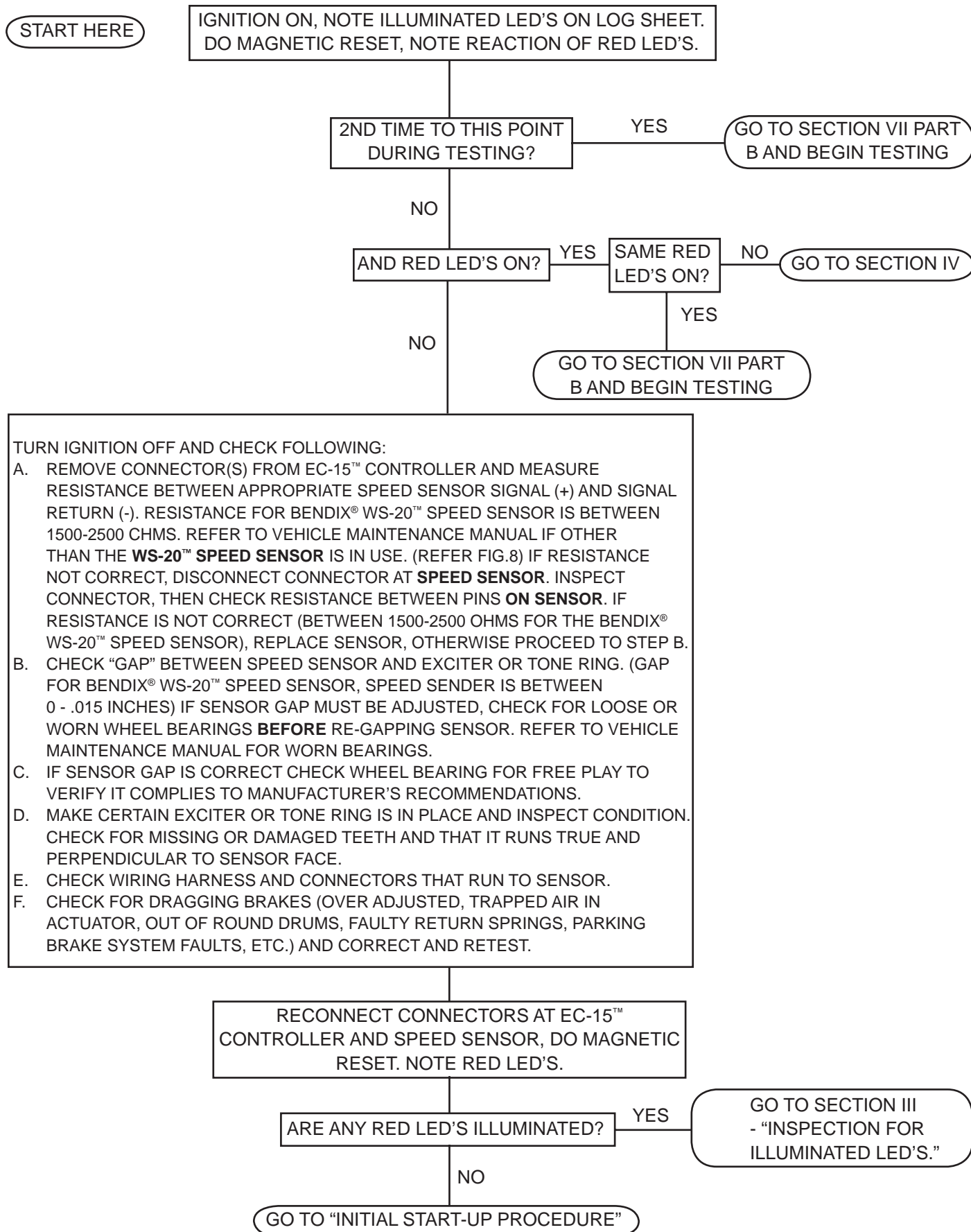

TROUBLESHOOTING

SECTION VI PART B - TESTING THE WHEEL SPEED SENSOR

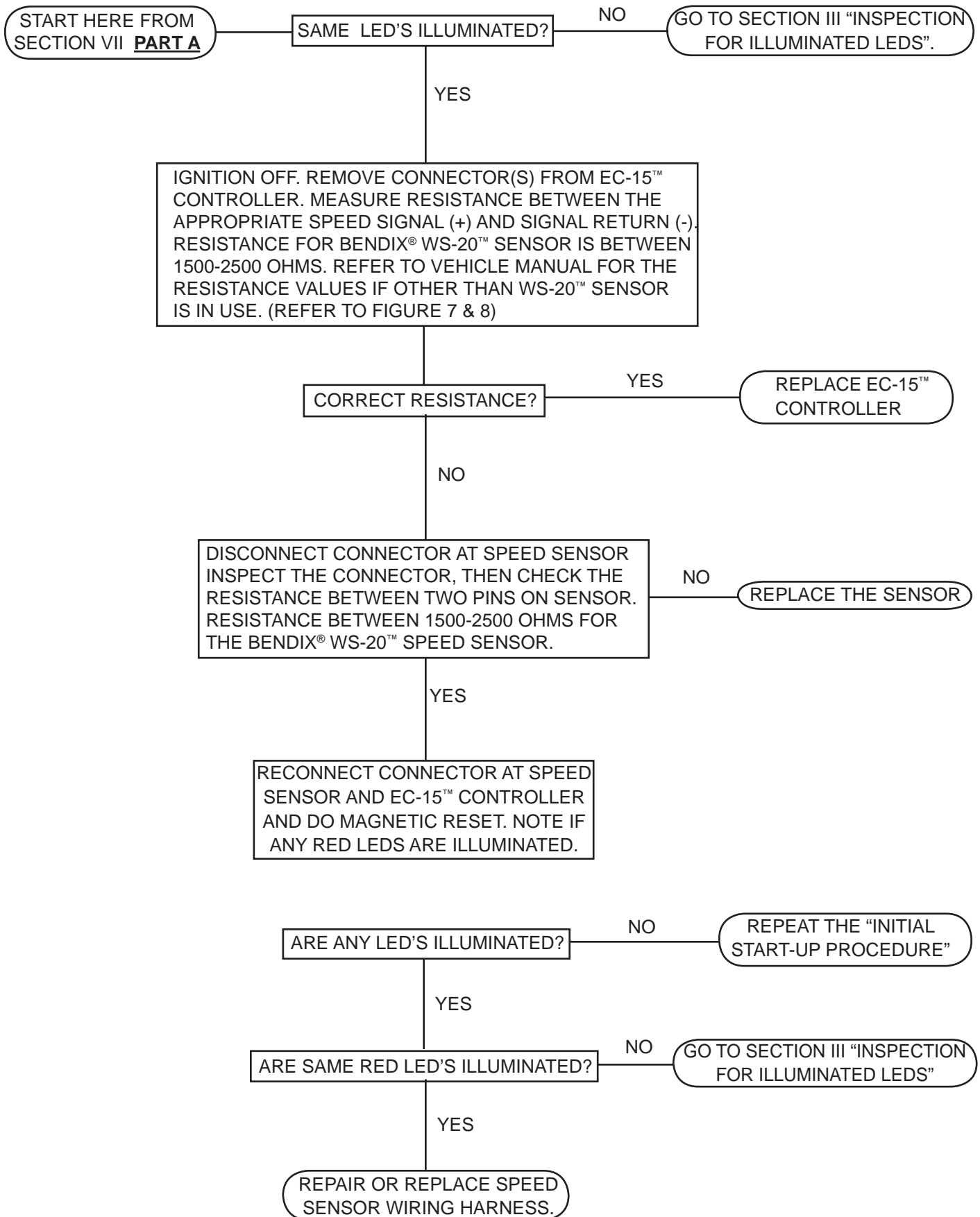

TROUBLESHOOTING

SECTION VIII - TESTING FOR FALSE INDICATION CAUSED BY DASH LIGHT RELAY

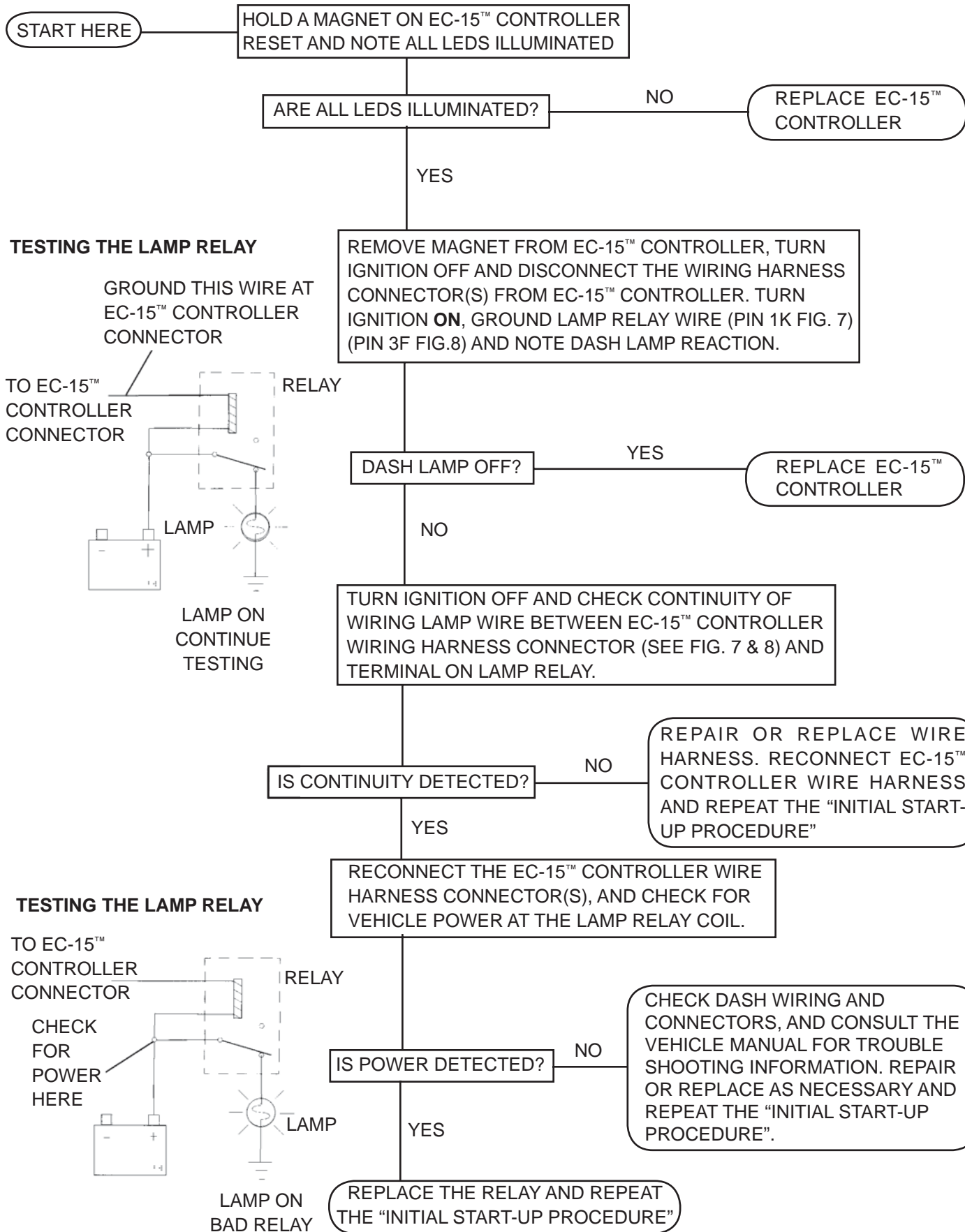

TROUBLESHOOTING

SECTION IX - TESTING FOR FALSE INDICATION CAUSED BY WHEEL SPEED COMPONENTS

