

# Protect Your Trailers from Dragging Brakes and Frozen or Clogged Air Lines

## Introducing the Bendix® Cyclone DuraDrain™ Trailer Water Separator

Trailer, converter dolly, and container chassis air lines can become traps for water and particulates that can slow down, even prevent, the proper operation of brakes when water and contaminants enter open glad-hands. The Cyclone DuraDrain™ trailer water separator provides **double** protection from both liquids and particulates when installed in **both** the supply and control air lines.

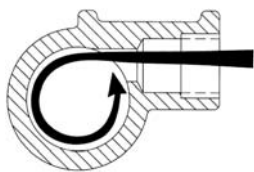
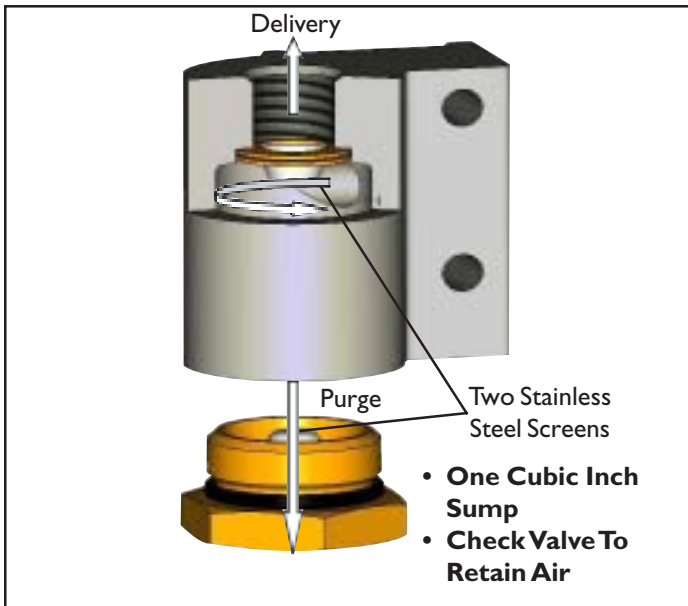

Water is spun in a vortex and automatically purged  
 – from the control line when brakes are released  
 – from the supply line when the parking brake is applied.



A spacer kit is offered to provide standoff clearance from trailer I-beams for service access (part number 5014792).

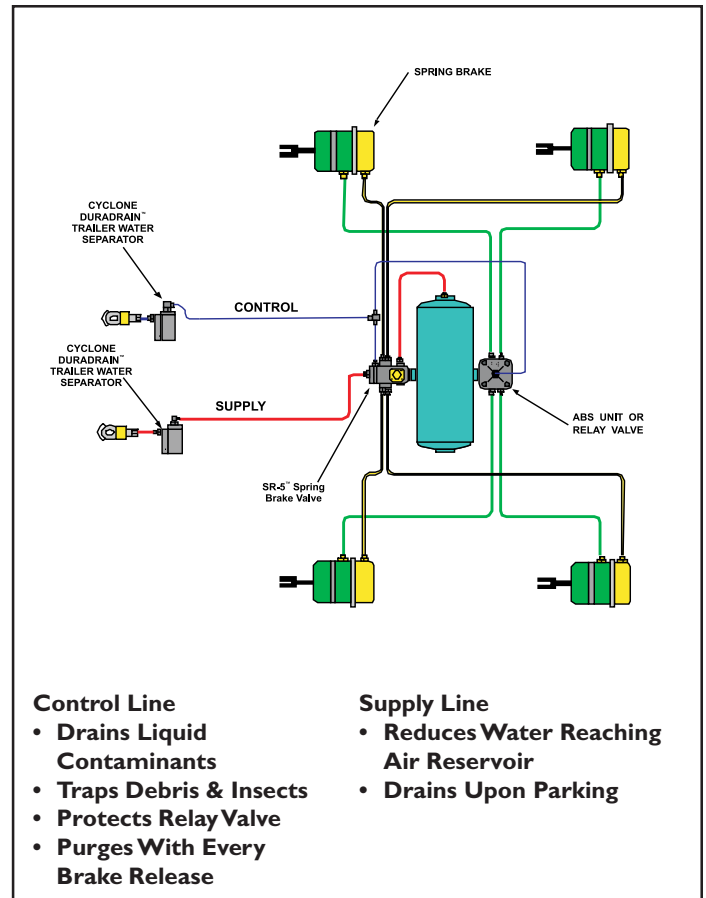

### Control Line

- Drains Liquid Contaminants
- Traps Debris & Insects
- Protects Relay Valve
- Purges With Every Brake Release

### Supply Line

- Reduces Water Reaching Air Reservoir
- Drains Upon Parking

Particulates are screened through stainless steel mesh to prevent being trapped in valve ports while clearing the way for continual air flow.

The Cyclone DuraDrain™ separator is now available for both OEM and Aftermarket retrofit (part number 801747) applications. Talk to your Bendix Account Manager, call 1-800-247-2725, or visit [www.bendix.com](http://www.bendix.com) today.

