

The combined stop light switch and double check valve, as the name implies, performs the function of a stop light switch and a double check valve. It operates in conjunction with the brake valve or hand control valve by completing the stop light electrical circuit and by directing the flow of air pressure into a common outlet line from either of the two inlet lines.

Weight - 0.81 lbs.

VMRS No. - 13-010-006

Device Code - 1850

NOTE: The DS-1 is **non-serviceable** & must be replaced with a complete assembly.

DS-1 is **not** available remanufactured exchange.

Switch to make contact at 5 p.s.i. (nominal)

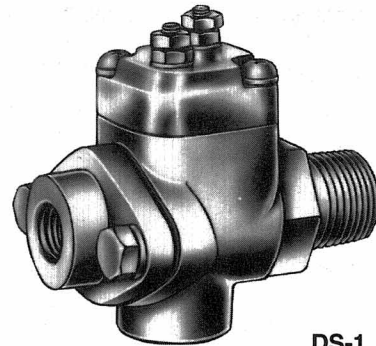

DS-1
Exterior

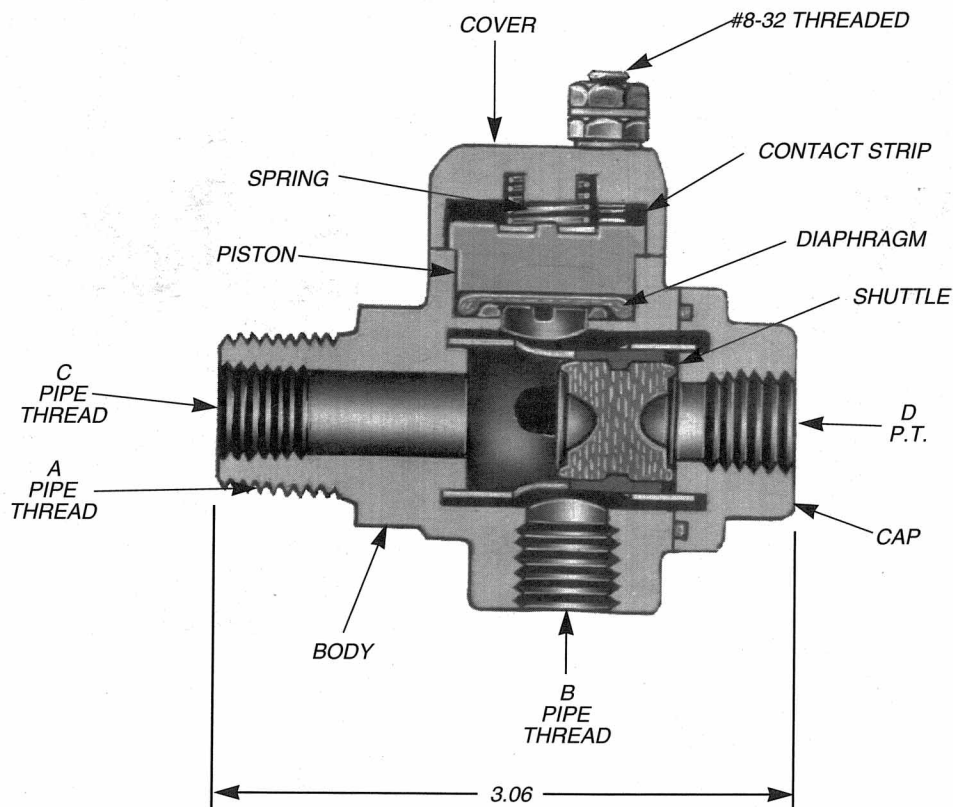

O.E. PIECE NO.	SERVICE PIECE NO.	THREAD SIZES (P.T.)				COMMENTS
		A	B	C	D	
228050	228050	1/2	1/4	—	1/4	—
228165	228165	3/8	1/4	—	1/4	—
228520	228520	1/2	3/8	—	1/4	—
229493	229493	1/2	1/4	1/4	1/4	—
275153	275153	1/2	3/8	—	1/4	Includes mounting bracket
276374	228050	1/2	1/4	—	1/4	—
276376	228520	1/2	3/8	—	1/4	—
283477	286704	3/8	3/8	—	1/4	Service replacement is a DS-2