

SLACK ADJUSTER

TYPE PL-55

CATALOG
05-A-10

STRAIGHT AND OFFSET ARMS DESIGNED FOR MAXIMUM TORQUE OF 55,000 IN. LBS.

WEIGHT — APPROX. 23 LBS.
VMRS #13-001-030 (FRONT)
13-002-028 (REAR)

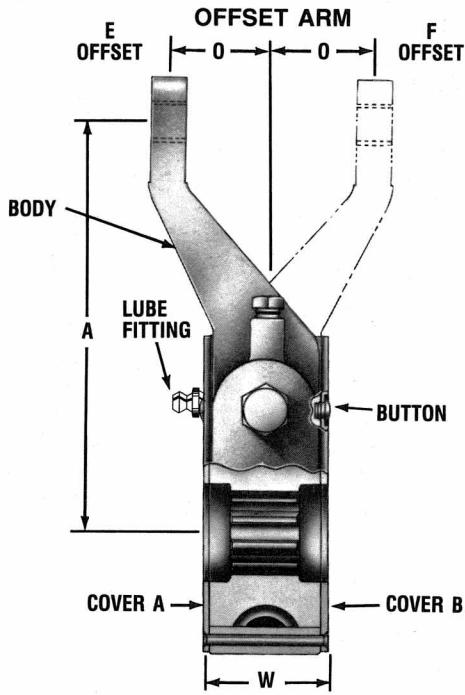

THE ABOVE ILLUSTRATION
SHOWS PROPER VIEWING
TO DETERMINE OFFSET

(OFFSET) ASSY. AND DETAIL REFERENCE

TYPE PL-55 SLACK ADJUSTER	OFFSET	O DIM'N. (IN.)	A DIM'N. (IN.)	HOLE BUSHING FOR A	BODY	COVER 2 REQ'D.		LUBE FITTING	BUTTON	W (WIDTH) IN.
						A	B			
17 TOOTH - 2 1/4" SPLINE (290565)										
102465	E	1	9 1/4	3/4	294612	290566	102995	214649	244400	3 1/8
102507	F	1	9 1/4	3/4	294617	290566	102995	214649	244400	3 1/8
10-B 1 3/4" SPLINE (249218)										
A284986	E	5/16	8	3/4	249221	249220	249219	—	242567	2 5/8
A284987	F	5/16	8	3/4	249222	294219	249220	—	242567	2 5/8

A - USE HOLE BUSHING 232121

HOLE BUSHING	D DIM'N.	MATERIAL
232121	3/4	SINTERED BRONZE
290240	3/4	STEEL

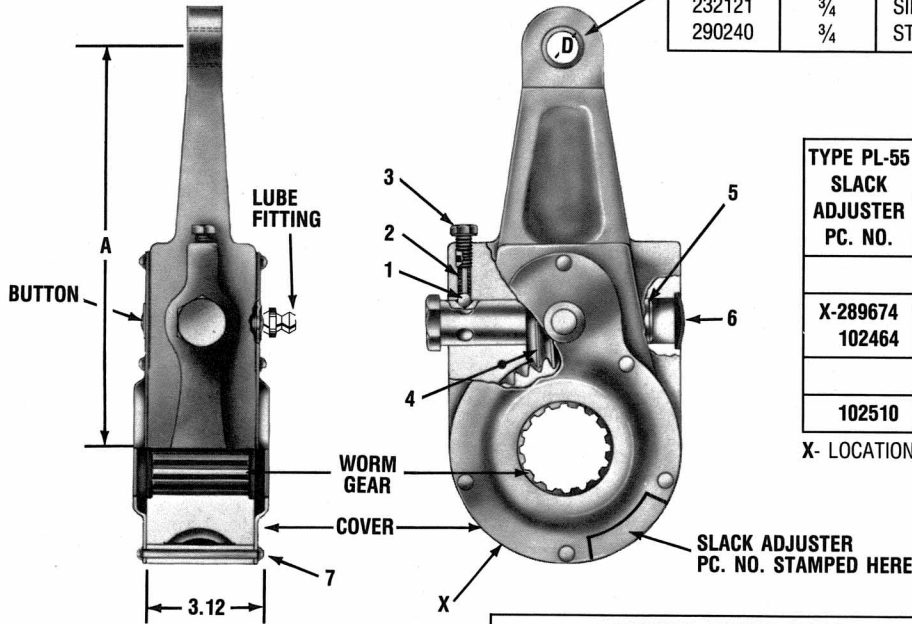

STRAIGHT ARM

(STRAIGHT) ASSY. AND DETAIL REFERENCE

TYPE PL-55 SLACK ADJUSTER PC. NO.	A DIM'N. (IN.)	HOLE BUSHING A	BODY	COVER (2 REQ'D.)	LUBE FITTING	BUTTON
16 TOOTH — 2 1/8" SPLINE (244553)						
X-289674	9 1/4	3/4	292767	244555	235342	242567
102464	10	3/4	294611	244555	214649	244400
17 TOOTH - 2 1/4" SPLINE (290565)						
102510	10	3/4	294611	290566	214649	244400

X- LOCATION OF LUBE FITTING FOR PC. NO. 289674

COMMON SERVICE PARTS THE FOLLOWING PARTS ARE COMMON TO ALL TYPE 55 SL. ADJ.

NO.	PC. NO.	QTY.	DESCRIPTION
1	204780	1	BALL
2	243326	1	SPRING
3	243327	1	ADJUSTING SCREW
4	239171	1	WORM
5	244554	1	WORM SHAFT
6	238496	1	WELCH PLUG
7	244556	6	RD. HD. RIVET

FOR SERVICE REPLACEMENT, SPECIFY ASSY. NUMBERS
LISTED ABOVE.