

DOUBLE CHECK VALVES

THE DOUBLE CHECK VALVE IS USED IN THE AIR BRAKE SYSTEM WHEN A SINGLE FUNCTION OR COMPONENT MUST BE CONTROLLED BY EITHER OF TWO VALVES. THE DOUBLE CHECK VALVE PERMITS EITHER, BUT NOT BOTH CONTROL VALVES TO OPERATE THE DEVICE CONNECTED TO ITS OUTLET PORT. AN EXAMPLE OF HOW THIS VALVE IS COMMONLY USED WOULD BE WHEN A TRAILER CONTROL VALVE (TC-2) IS INSTALLED ON A TRACTOR AND BOTH THE SERVICE FOOT BRAKE VALVE AND TRAILER CONTROL VALVE MUST APPLY THE TRAILER BRAKES.

DOUBLE CHECK VALVES ARE AVAILABLE IN VARIOUS CONFIGURATIONS FOR DIFFERENT VEHICLE APPLICATIONS.

FOR SERVICE/MAINTENANCE INFORMATION, SEE SERVICE DATA SHEET SD-03-67.

VMRS NO. 13-010-092.

DEVICE CODE IS 2202.

CHECK VALVES NOT AVAILABLE IN REMFR. EXCH.

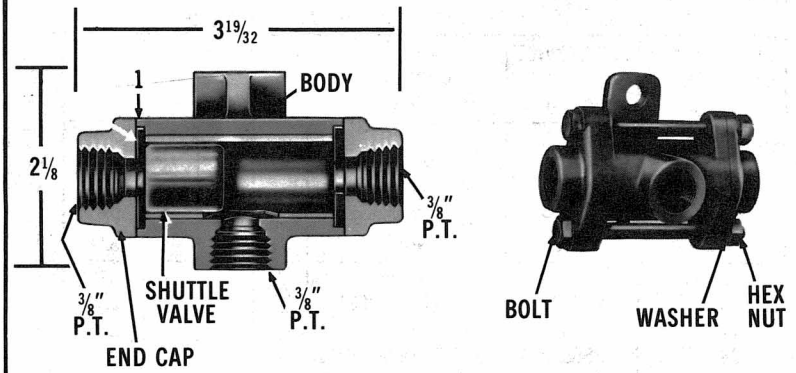

SUB ASSY. AND DETAIL REFERENCE

DC-1 DOUBLE CHECK VALVE PC. NO.	FOR SERVICE USE PC. NO.	SHUTTLE VALVE PC. NO.
217698	217698	235561
B280479	280479	245043

B—SUBSTITUTE FOUR (4) CAP SCREWS & LOCKWASHERS 239383 FOR HEX NUT, LOCKWASHER & BOLT

COMMON SERVICE PARTS

NO.	PC. NO.	QTY.	DESCRIPTION
1	235562	2	Seal Gasket

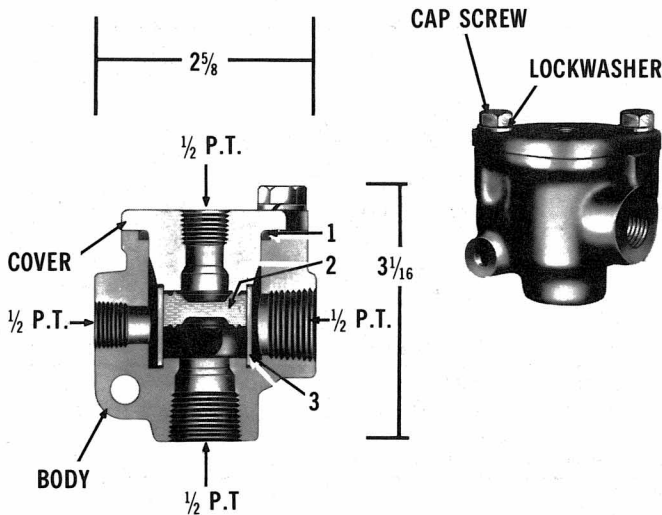

DC-2 DOUBLE CHECK VALVE
PC. NO. 223869

NO.	PC. NO.	QTY.	DESCRIPTION
1	233955	1	GROMMET
2	240135	1	VALVE
3	239950	1	VALVE GUIDE

FOR SERVICE, USE PC. NO. 223869

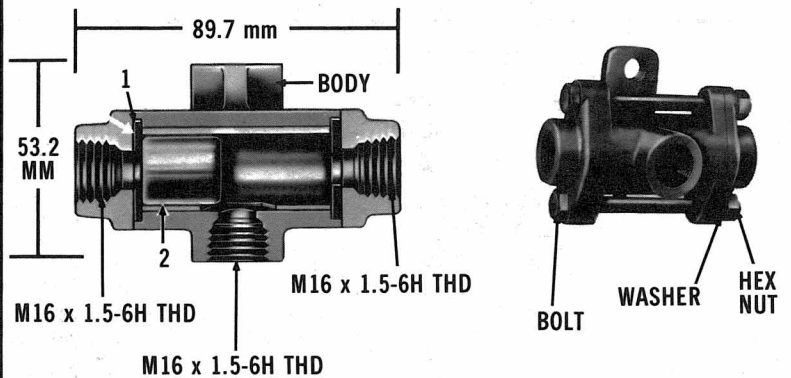

DC-1 DOUBLE CHECK VALVE
PC. NO. 286431

NO.	PC. NO.	QTY.	DESCRIPTION
1	235562	2	SEAL GASKET
2	235561	1	SHUTTLE VALVE

THIS DEVICE IS METRIC-CUSTOMER IS VOLVO FOR SERVICE, USE PC. NO. 286431

DOUBLE CHECK VALVES

SERVICE PARTS CATALOG 03-A-6B

SUB ASSY. AND DETAIL REFERENCE

DC-4 DOUBLE CHECK VALVE PC. NO.	FOR SERVICE USE PC. NO.	CUSTOMER IDENTIFICATION	A P.T.	B P.T.	C P.T.	D DIM'N	E P.T.	F P.T.	G P.T.
278595	278595	NONE	1/4	1/2	1/4	2.75	1/4	—	—
278596	278596	NONE	3/8	1/2	1/4	2.75	3/8	—	—
278597	278597	NONE	1/4	3/8	1/4	2.75	1/4	—	—
278598	278598	NONE	3/8	3/8	1/4	2.75	3/8	—	—
278599	278599	NONE	3/8	1/2	3/8	3.00	3/8	—	—
280809	280809	NONE	3/8	3/8	3/8	3.00	3/8	—	—
285542	278597	TEREX 2463081	1/4	3/8	1/4	2.75	1/4	—	—
A 285683	285683	NONE	—	—	1/4	2.50	—	1/4	1/4
287178	285683	FORD D4HA-2K119-AA	—	—	1/4	2.50	—	1/4	1/4
B 287179	287179	FORD D5HA-2K119-BA	3/8	—	1/4	2.50	1/4	1/4	—
287180	287180	FORD D5HA-2K119-AA	3/8	3/8	1/4	2.75	1/4	—	—
287626	280809	KENWORTH K295-141	3/8	3/8	3/8	3.00	3/8	—	—
287627	280809	WHITE 72404-0002	3/8	3/8	3/8	3.00	3/8	—	—
289296	289296	MACK 20QE2199R	3/8	3/8	3/8	3.00	1/4	—	—

A-ADD TEFLON TAPE TO "G" MALE P.T.
B-ADD NIPPLE, 214296 IN "F" PORT

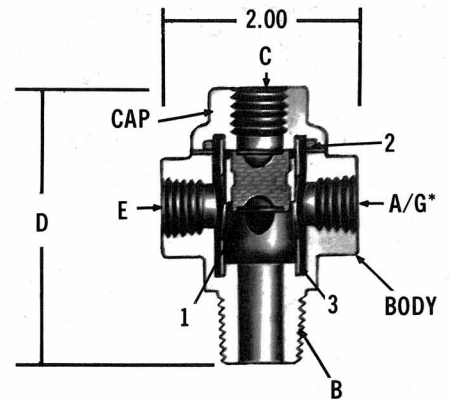
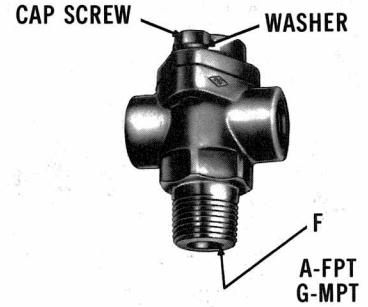

COMMON SERVICE PARTS			
NO.	PC. NO.	QTY.	DESCRIPTION
1	237497	1	SHUTTLE
2	239658	1	O-RING
3	239949	1	SHUTTLE GUIDE

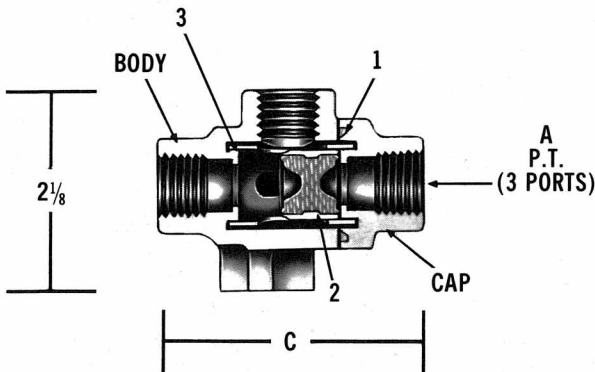
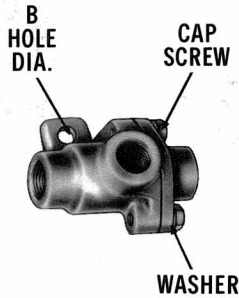

SUB ASSY. AND DETAIL REFERENCE

DC-4 DOUBLE CHECK VALVE PC. NO.	FOR SERVICE USE PC. NO.	CUSTOMER IDENTIFICATION	A PIPE THD. (3)	B HOLE DIA.	C DIM'N
277988	283321	MACK 20QE283R	3/8	13/32	2 7/32
278614	278614	NONE	3/8	11/32	2 7/32
278615	278615	NONE	1/4	13/32	2 9/32
283321	283321	NONE	3/8	13/32	2 7/32
286414	278614	IHC 764368-C92	3/8	11/32	2 7/32
287181	278614	FORD-D5TA-2K119-AA	3/8	11/32	2 7/32
287628	278614	WHITE 72404-0001	3/8	11/32	2 7/32
288334	278615	WHITE 72404-0012	1/4	13/32	2 9/32
289547	289547	NONE	1/4	11/32	2 9/32

COMMON SERVICE PARTS			
NO.	PC. NO.	QTY.	DESCRIPTION
1	239658	1	O-RING
2	237497	1	SHUTTLE VALVE
3	239949	1	SHUTTLE GUIDE