

WITH PRESS, REGULATOR & DOUBLE CHECK VALVE

The VM-3 serves as a control manifold providing a central location for air lines passing between the cab and engine compartment. The control function is accomplished with the double check valve and PR-4 pressure protection valve housed in the VM-3.

For complete service/maintenance information, see Service Data Sheet SD-03-59.

WEIGHT-4 lbs. 2 oz.

VMRS. NO. 13-010-116

MAINTENANCE KIT FOR VM-3 IS PC. NO. 289062.

DEVICE CODE IS 3410.

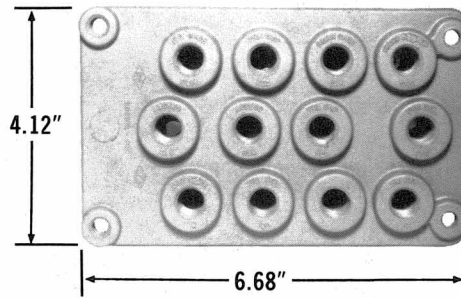

BOTTOM VIEW

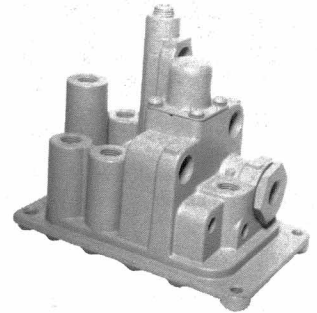

VM-3 NOT AVAILABLE IN REMFR. EXCH.

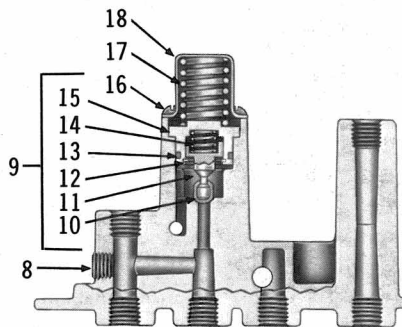
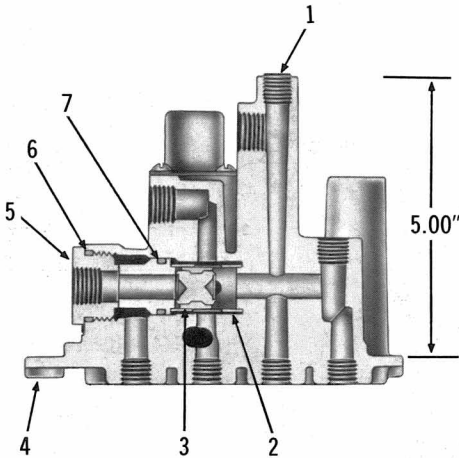

VM-3 MANIFOLD WITH PRESS, REGULATOR & DOUBLE CHECK VALVE							
PC. NO. 288645							
NO.	PC. NO.	QUAN.	DESCRIPTION	NO.	PC. NO.	QUAN.	DESCRIPTION
1	230576	1	PIPE PLUG, 1/4"	9	288484	1	PISTON ASSY.
2	239949	1	SHUTTLE GUIDE	10	A	1	INLET & EXHAUST VALVE
3	A	1	SHUTTLE VALVE	11	292059	1	STEM
4	292102	1	BODY	12	237345	1	RETAINING RING
5	292103	1	CAP NUT	13	A	1	O-RING
6	A	1	O-RING	14	292058	1	SPRING
7	A	1	O-RING	15	292057	1	PISTON
8	248397	1	PIPE PLUG	16	292275	1	#10 MACH. SCREW
				17	292916	1	SPRING
				18	292104	1	SPRING RETAINER

A - FURNISHED IN MAINTENANCE KIT PC. NO. 289062