

# SPRING BRAKE ACTUATOR

SB-1

CATALOG  
02-W-1

The SB-1 spring brake actuator is a pull type, remote-mounted air cylinder that is used as a parking brake. Pressurized air in the chamber compresses the springs when the brake is released. When the air is exhausted, the spring force applies the brake.

Weight - 21.4 lbs.  
VMRS No. - 13-010-025  
Device Code - 4500

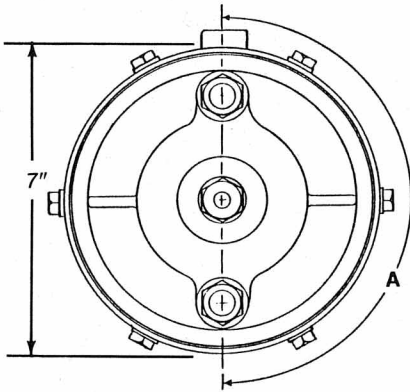
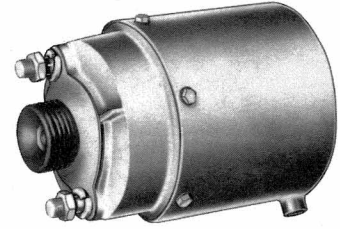

STUD END VIEW

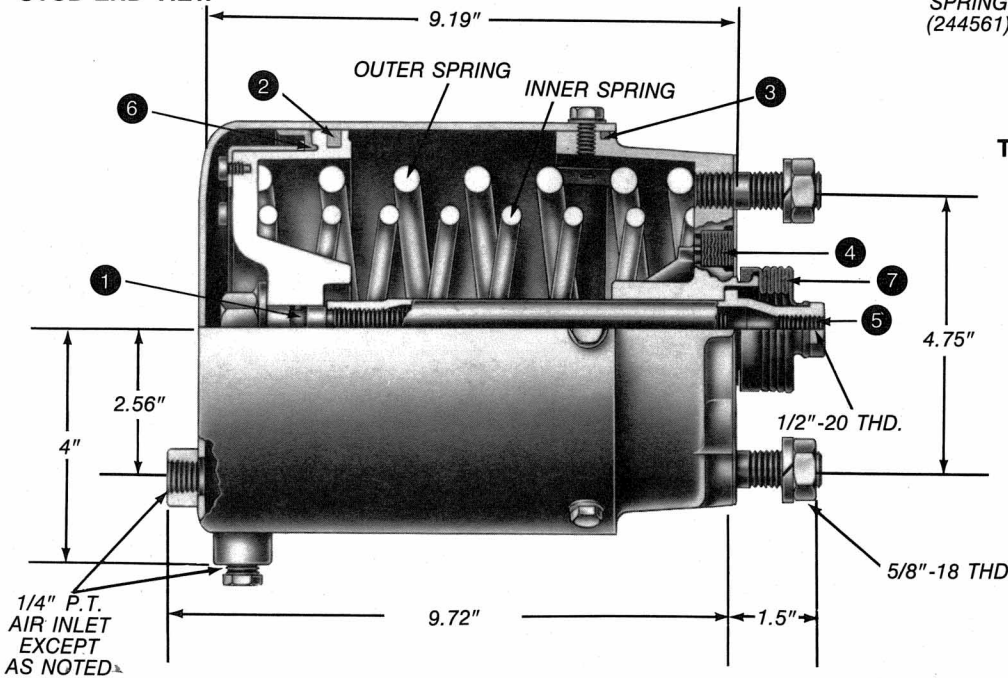

## SERVICE PARTS

KEY NO.	QTY.	DESCRIPTION	PC. NO.
1	1	O-Ring	239136
2	1	Felt Oiler	240536
3	1	Sealing Ring	236728
4	1	Felt Breather	240556
5	1	Pull Rod	240783
6	1	Piston Cup	240311
7	1	Boot	243481

AUXILIARY SPRING  
(244561)

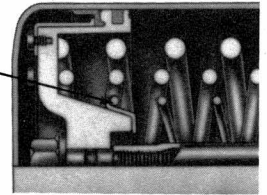

THREE SPRING CONFIGURATION  
(PC. NOS. 279847, 280080)

PC. NO.	CUSTOMER ID. LABEL	A° (FERRULE LOCATION)	SPRG. LOAD 0"	SPRG. LOAD AT MAX. STROKE	MAX. STROKE	OPEN INLET LOCATION	INNER SPRG.	OUTER SPRG.	NOTES
275787		0	845#	1695#	3.75"	END	240914	240913	
275788		0	845#	1695#	3.75"	SIDE	240914	240913	
275789		180	845#	1695#	3.75"	SIDE	240914	240913	
276180		0	510#	905#	3.75"	END	NONE	240913	
277916		0	845#	1695#	3.75"	SIDE	240914	240913	3/8" AIR INLET
279283		0	510#	720#	2"	END	NONE	240913	
279847		180	890#	1935#	3.75"	END	240914	240913	AUX. SPRG.
280080	19QE3100C	180	890#	1935#	3.75"	END	240914	240913	AUX. SPRG.
280108		0	335#	790#	3.75"	END	240914	NONE	